



CETRA²⁰¹²

2nd International Conference on Road and Rail Infrastructure
7–9 May 2012, Dubrovnik, Croatia

Road and Rail Infrastructure II

Stjepan Lakušić – EDITOR



Organizer
University of Zagreb
Faculty of Civil Engineering
Department of Transportation



CETRA²⁰¹²
2nd International Conference on Road and Rail Infrastructure
7–9 May 2012, Dubrovnik, Croatia

TITLE

Road and Rail Infrastructure II, Proceedings of the Conference CETRA 2012

EDITED BY

Stjepan Lakušić

ISBN

978-953-6272-50-1

PUBLISHED BY

Department of Transportation
Faculty of Civil Engineering
University of Zagreb
Kačićeva 26, 10000 Zagreb, Croatia

DESIGN, LAYOUT & COVER PAGE

minimum d.o.o.
Katarina Zlatec · Matej Korlaet

COPIES

600

A CIP catalogue record for this e–book is available from the National and University Library in Zagreb under 805372

Although all care was taken to ensure the integrity and quality of the publication and the information herein, no responsibility is assumed by the publisher, the editor and authors for any damages to property or persons as a result of operation or use of this publication or use the information's, instructions or ideas contained in the material herein.

The papers published in the Proceedings express the opinion of the authors, who also are responsible for their content. Reproduction or transmission of full papers is allowed only with written permission of the Publisher. Short parts may be reproduced only with proper quotation of the source.

Proceedings of the
2nd International Conference on Road and Rail Infrastructures – CETRA 2012
7–9 May 2012, Dubrovnik, Croatia

Road and Rail Infrastructure II

EDITOR

Stjepan Lakušić

Department of Transportation

Faculty of Civil Engineering

University of Zagreb

Zagreb, Croatia

CETRA²⁰¹²

2nd International Conference on Road and Rail Infrastructure

7–9 May 2012, Dubrovnik, Croatia

ORGANISATION

CHAIRMEN

Prof. Željko Korlaet, University of Zagreb, Faculty of Civil Engineering
Prof. Stjepan Lakušić, University of Zagreb, Faculty of Civil Engineering

ORGANIZING COMMITTEE

Prof. Stjepan Lakušić
Prof. Željko Korlaet
Prof. Vesna Dragčević
Prof. Tatjana Rukavina
Maja Ahac
Ivo Haladin
Saša Ahac
Ivica Stančerić
Josipa Domitrović

All members of CETRA 2012 Conference Organizing Committee are professors and assistants of the Department of Transportation, Faculty of Civil Engineering at University of Zagreb.

INTERNATIONAL ACADEMIC SCIENTIFIC COMMITTEE

Prof. Ronald Blab, Vienna University of Technology, Austria
Prof. Vesna Dragčević, University of Zagreb, Croatia
Prof. Nenad Gucunski, Rutgers University, USA
Prof. Željko Korlaet, University of Zagreb, Croatia
Prof. Zoran Krakutovski, University Sts. Cyril and Methodius, Rep. of Macedonia
Prof. Stjepan Lakušić, University of Zagreb, Croatia
Prof. Dirk Lauwers, Ghent University, Belgium
Prof. Giovanni Longo, University of Trieste, Italy
Prof. Janusz Madejski, Silesian University of Technology, Poland
Prof. Jan Mandula, Technical University of Kosice, Slovakia
Prof. Nencho Nenov, University of Transport in Sofia, Bulgaria
Prof. Athanassios Nikolaidis, Aristotle University of Thessaloniki, Greece
Prof. Otto Plašek, Brno University of Technology, Czech Republic
Prof. Christos Pyrgidis, Aristotle University of Thessaloniki, Greece
Prof. Carmen Racanel, Technical University of Bucharest, Romania
Prof. Stefano Ricci, University of Rome, Italy
Prof. Tatjana Rukavina, University of Zagreb, Croatia
Prof. Mirjana Tomičić–Torlaković, University of Belgrade, Serbia
Prof. Brigita Salaiova, Technical University of Kosice, Slovakia
Prof. Peter Veit, Graz University of Technology, Austria
Prof. Marijan Žura, University of Ljubljana, Slovenia

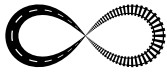

FEM DRIVEN DESIGN PROCESS OF INNOVATIVE INTERMODAL TRUCK–RAIL SOLUTION

Wieslaw Krason, Tadeusz Niezgodą, Krzysztof Damaziak

Department of Mechanics and Applied Computer Science,

Faculty of Mechanical Engineering, Military University of Technology, Poland

Abstract

A few years ago, the constructors from the Department of Mechanics and Applied Computer Science of the Military University of Technology in Warsaw began to work on the concept of an innovative wagon for truck transportation. The main design goal was to develop a solution which would allow easy load/unload procedure without extensive railway infrastructure changes. The concept of the solution took a form of a special wagon with the moving (rotating) central part. In short, the rotating part acts as a kind of a bridge allowing a truck to move through it during load/unload. During railway operation, this rotating 'bridge' is to become an integrated part of the wagon. Since the design team aimed at very challenging demands of DB1 envelope and usage of standard bogies, the layout of the wagon had to be carefully examined in terms of its overall stiffness. A unique concept of the wagon structure forced a design approach which was rather unusual for the rail industry. Instead of analyzing the almost finally developed, validated in terms of technology, structure (usual approach), numerical simulations had to be included as an immanent part of the design process. Every major design change had to be simulated in order to accurately predict its influence on the whole wagon structure. It should be stressed out that such an approach (mainly multibody [1, 2] and FE analysis [3]), although time consuming, was the only way to access information how design changes would affect wagon's mechanics. Without this knowledge design of the new wagon would not have been possible.

Keywords: innovative railway wagon for truck transportation, structure modifications, FE analysis in design process

1 Introduction

A special wagon, presented in the paper, can be used for railway transport of semitrailers and TIR type vehicles. It enables transport of vehicles of 36 tons mass and height of 4m on the GB1 clearance height. Such a wagon is equipped with a frame–support with marginal parts mounted on standard biaxial bogies and the central part lowered in respect to the marginal parts along declining walls, a rotating loading platform mounted vertically over the central part of the frame–support. Such a structure can be used for transporting various types of vehicles, for example, tractors, trucks, trailers, semitrailers, cargo containers. The railway wagon allows quick and convenient loading and unloading of vehicles and containers (no cranes needed), self loading and unloading; no platform infrastructure is required, instead of hardened, flat, surface; no need for hubs, terminals or special logistics; each wagon can be operated separately.

The model of a railway wagon for truck transport on the scale 1:14 was developed in the Laboratory of Materials Strength of the Department of Mechanics and Applied Computer Science,

Military University of Technology [4]. The model mapped essential components of the wagon and infrastructure of the loading–unloading railway platform. There was applied pneumatic supply, steering and actuators in the mechanism of rotation of the moving platform of the wagon body as well as for stiffening the construction with the use of additional supports of the wagon bottom and locking the pin joint type locks between the over–bogie part of the wagon and the tailboards of the body platform. Figure 1 demonstrates the photos illustrating constructing and basic functions of the model of the railway wagon for transport of trucks on the scale 1:14.

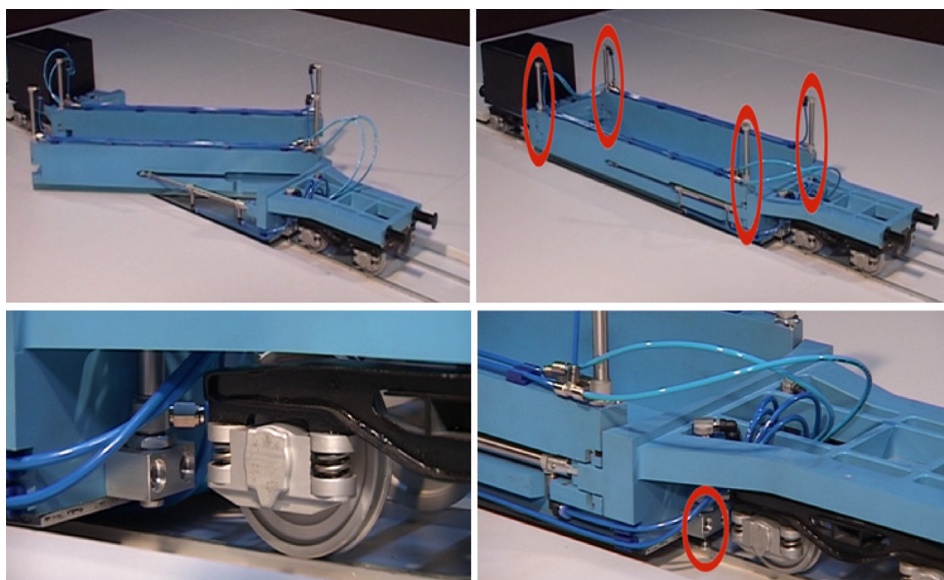

Figure 1 Model of the special wagon for railway transport of semitrailers developed in Military University of Technology – model with the main wagon assemblies on the scale 1:14 [4].

The discussed model enables demonstration of the principle of operations and visualization of basic functions of the railway wagon for transport of trucks – Figure 2. The model served also to prepare kinematic simulations of the real cooperation of wagon subsystems with the rotatable platform of the body.

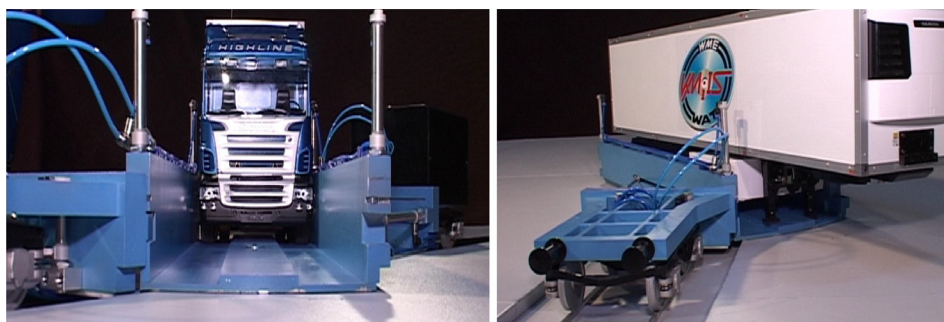

Figure 2 Model of the special wagon for intermodal transport – selected views of the semitrailer loading from a railway ramp.

These analyses enabled to estimate the fluency of motions of the cooperating wagon mechanisms, made possible detecting of potential cuts and initial identification of critical states concerning the run of loading/unloading operations and a proper transport phase from constructional–operating point of view.

2 Numerical models of the special railway wagon for intermodal transport

2.1 Structure modifications and geometrical model of innovative wagon

An initial solution of the special railway wagon presented above is burdened with certain constructional problems. Firstly, mounting of the actuators in the side wall of the rotatable platform, connected with the still part of the wagon, reduce the loading capabilities of the wagon (a wagon can rotate only in one direction). Moreover, such position of the actuators as well as mounting vertical actuators driving pivotal locks (Figure 1) extorts conveying the wires powering the hydraulic elements through the central rotating junction of the platform. It increases significantly their length and also increases the risk of their wearing.

In connection with above, it was decided to modify the construction of the wagon so as to eliminate the mentioned problems concerning this solution.

The following constructional modifications were introduced in the next version of the wagon for intermodal transport:

- a changing of the mechanism of the platform body rotation,
- b modifications of the buckles connecting the body with the over–bogie part of the wagon frame,
- c changing of the body rotating platform (height and an open work construction of the tailboards, construction of the central bearing and rotation junction),
- d modifications of the structure of the over–bogies part of the wagon frame with a raceway of the rotatable platform.

All the main constructional modifications mentioned above were visualized and interpreted by descriptions in figures 3–6.

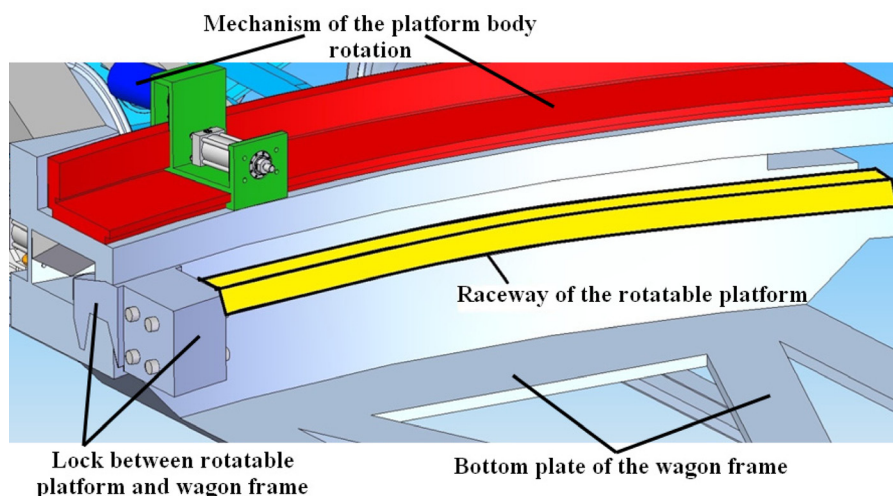

Figure 3 Geometrical model of the special wagon for intermodal transport – modifications of the mechanism of the platform body rotation.

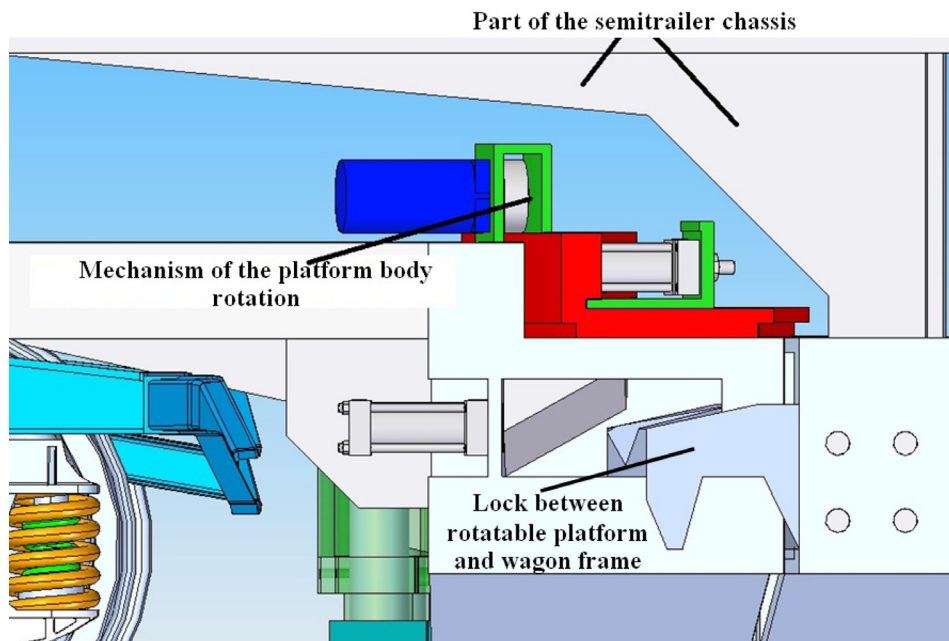

Figure 4 Geometrical model of the special wagon for intermodal transport – modifications of the locks connecting the body with the over-bogie part of the wagon frame.

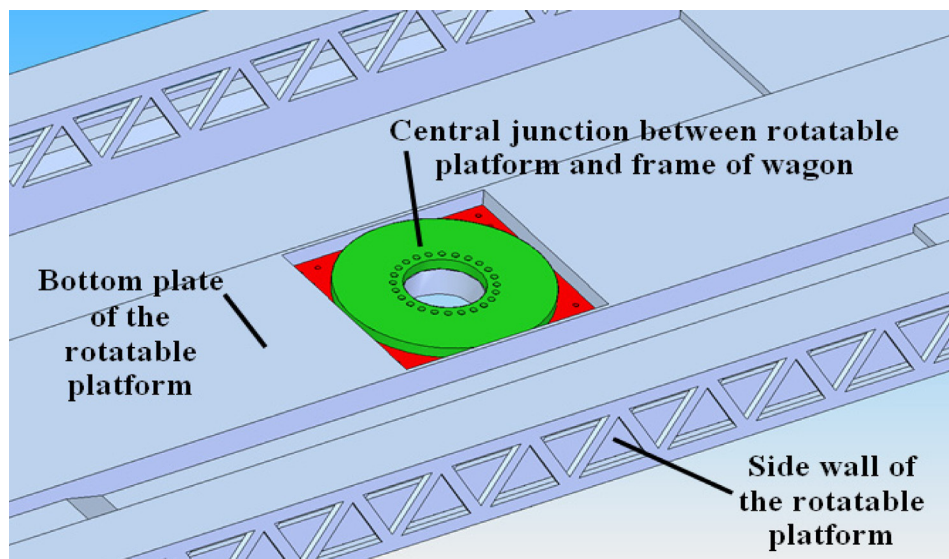

Figure 5 Geometrical model of the special wagon for intermodal transport – modifications of the body rotatable platform.

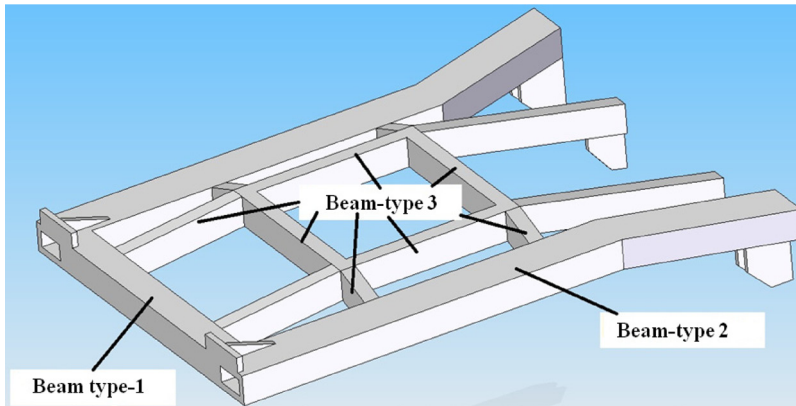

Figure 6 Geometrical model of the special wagon for intermodal transport – modifications of the structure of the over-bogie part of the wagon frame.

2.2 FE model of the special wagon with structure modifications

Selected problems of numerical analysis of the constructional solution of a wagon with a rotatable platform, with constructional changes taken into consideration, will be the object of considerations presented in the paper. The introduced constructional changes caused that wagon – unlike the prior version [4] discussed in the previous part of the study – became a symmetric construction. It was decided to use this fact and to conduct the calculations of a new version on the basis of $\frac{1}{4}$ of the model. It should be underlined, that the range of constructional changes extorted preparation of a completely new mesh of finite elements [3]. The new numerical model, presented in Figure 7, consisted of 203650 nodes and approximately 200000 elements.

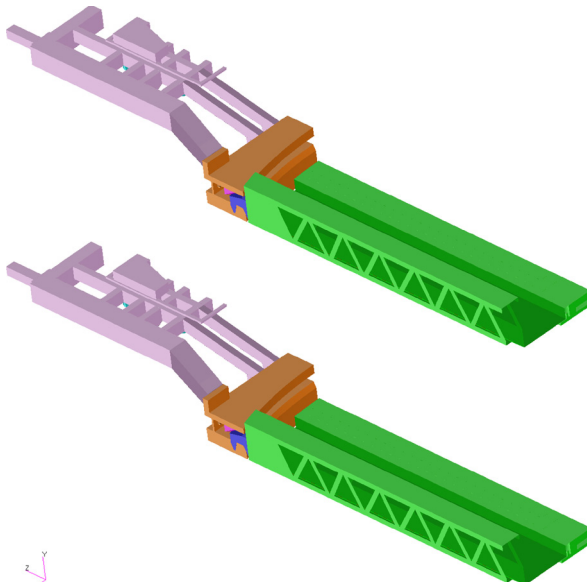

Figure 7 FE model of the part of the wagon after constructional modifications – top and bottom views.

3 FE numerical analysis

3.1 Some aspects of boundary conditions modelling

Based on the prior works, it was decided that the limiting variant for the wagon is the case of loading described in PN-EN 12663 standard [6] as 'the maximal service loading', depicted with a formula $1,95 \times g \times (m_1 + m_2)$ where: m_1 – mass of a vehicle body in the state ready to work, m_2 – load allowed mass, g – g gravitational acceleration. In the numerical FE model, the standard [6] loading was implemented by applying inertia forces resulting from the value of the standard acceleration to the whole structure and by defining the load, of the value corresponding to the allowed mass of the vehicle semitrailer enlarged by a coefficient 1.95, acting on the central rotating junction (Figure 5). Due to taking into consideration the symmetry, the latter quantity was fourfold reduced. Deviation from the real areas of applying the loading (wheels of a semitrailer) was caused by the wish of maintaining the symmetry of the task. On the other hand, the considered case is more unfavourable in relation to the real one.

Just as in the case of previous analyses [4], boundary conditions in the king-pin are different than standard ones since besides displacements in the wagon plane, the possibility of the rotation around the longitudinal axis is taken away. This deviation results in the fact that deflection calculated during analyses presents significantly lower values, however, on the other hand, the strains in the structure (especially in an over-bogie part of the wagon frame) should be extorted.

The applied manner of the support can be treated as an attempt of taking into consideration other cases described in the standard [6] (for example, the case of lifting the wagon) and it is justified to the extend that the described analyses are purposed at supplying the information required for conducting constructional works but are not strictly verifying calculations.

3.2 Numerical results

The selected results of analysis [3] of the structure of the wagon with a plate floor corresponding to the described in 3.1 section variant of boundary conditions are presented in Figure 8–9.

From the presented numerical tests, it results that it is still necessary to introduce some constructional improvements such as, for example, additional elements supporting work of the locks between the part of the rotatable platform walls and the over-bogie part of the wagon frame.

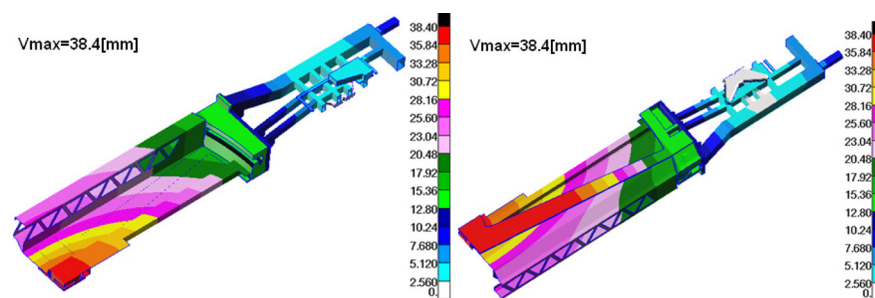

Figure 8 Maps of displacements – top and bottom views.

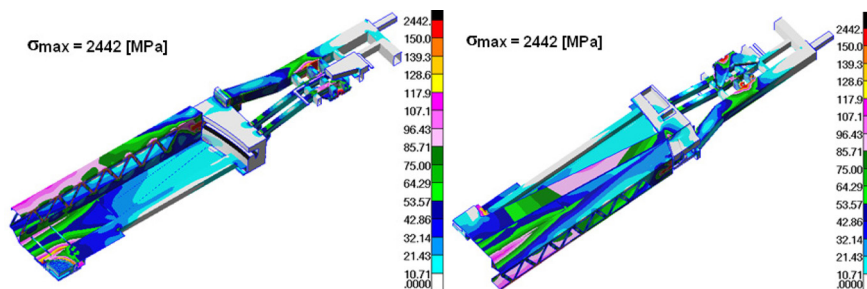

Figure 9 Maps of reduced HMM stresses – top and bottom views.

4 Summary

The methodology of numerical investigation, FEM models applied in the tests, verifying analyses and in simulating investigations of a wagon with a rotating platform and the obtained results are possible to be used in research – development works in the range of the design and modernization of such constructions in the scope of extending their service lives.

The developed methodology of examination of such a construction enables its implementation both at the stage of the design and during tests on already exploited or renovated constructions. Based on conducted analyses it can be verified that the proposed conception can meet the standard criteria included in PN-EN 12663 [6], however, some of its fragments require further analysis and tests. These elements are:

- optimization and strengthening of the construction of the over–bogie part of the wagon frame, especially modifications in the areas of mounting the tailboards joints of the rotatable platform, in which stresses concentrations occur locally,
- stiffening of the floor part of the rotating platform and optimization of the floor shape in order to limit deflection at loading with double masses – own and load,
- optimization of tailboards dimensions which, in the present form, are not strained, what allows to consider that in the optimization process it will be possible to significantly reduce their mass.

The work is financed by National Center of Research and Development – PBR R10 0023 06/2009 Presented constructional solution is protected by European patent application – EP 10461528

References

- [1] Zhenfgang Lu, Hecht M.: Dynamic analysis of a new double deck passenger vehicle with bogie PW200, Technische Universität Berlin.
- [2] Matej J., Piotrowski J., Wojtyra M., Frączek J.: Modelling and safety examination of the long bimo dal train on curved track Rusing ADAMS/Rail, Institute of Vehicles, Warsaw University of Technology.
- [3] Zienkiewicz o. c, Taylor R.L.: The finite element method. V-edition, McGraw-Hill, London, 2000.
- [4] Niezgodą T., Krasoń W., Barnat W., Sławiński G.: Badania numeryczne rozwiązań prototypowych mechanizmu obrotu platformy wagonu kolejowego do przewozu naczep typu T1R, Problemy Kolejnictwa, Instytut Kolejnictwa, Zeszyt 153, str. 137-146, Warszawa, 2011, (in polish).
- [5] MSC.Patran/Marc, Manual, MSC, 2005.
- [6] PN-EN 12663: Railway applications - Structural requirements of railway vehicle bodies, Warsaw, 2002.