



CETRA 2016

4th International Conference on Road and Rail Infrastructure
23-25 May 2016, Šibenik, Croatia

Road and Rail Infrastructure IV

Stjepan Lakušić – EDITOR

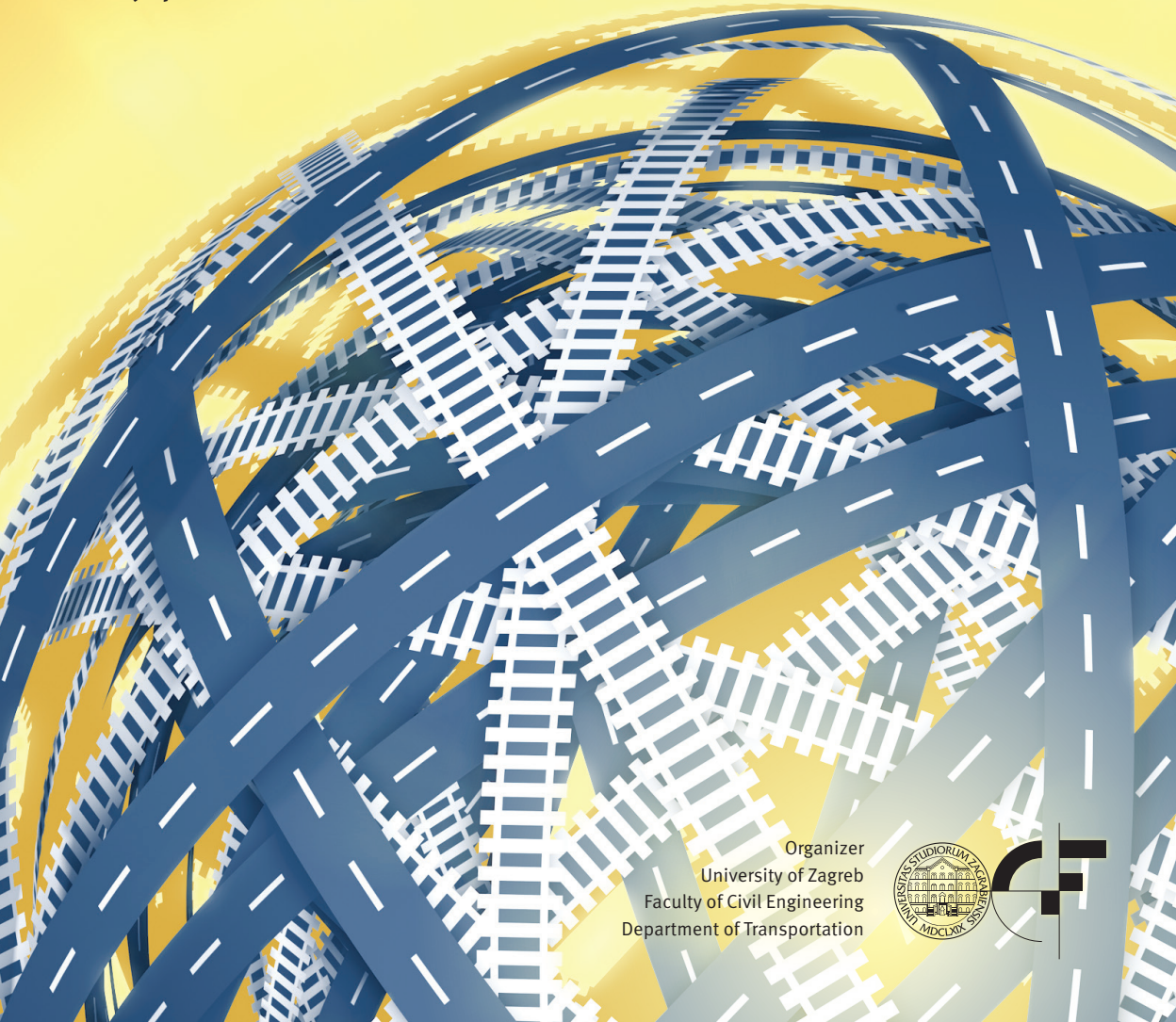

Organizer
University of Zagreb
Faculty of Civil Engineering
Department of Transportation



CETRA²⁰¹⁶

4th International Conference on Road and Rail Infrastructure
23–25 May 2016, Šibenik, Croatia

TITLE

Road and Rail Infrastructure IV, Proceedings of the Conference CETRA 2016

EDITED BY

Stjepan Lakušić

ISSN

1848-9850

PUBLISHED BY

Department of Transportation
Faculty of Civil Engineering
University of Zagreb
Kačićeva 26, 10000 Zagreb, Croatia

DESIGN, LAYOUT & COVER PAGE

minimum d.o.o.

Marko Uremović · Matej Korlaet

PRINTED IN ZAGREB, CROATIA BY

“Tiskara Zelina”, May 2016

COPIES

400

Zagreb, May 2016.

Although all care was taken to ensure the integrity and quality of the publication and the information herein, no responsibility is assumed by the publisher, the editor and authors for any damages to property or persons as a result of operation or use of this publication or use the information's, instructions or ideas contained in the material herein.

The papers published in the Proceedings express the opinion of the authors, who also are responsible for their content. Reproduction or transmission of full papers is allowed only with written permission of the Publisher. Short parts may be reproduced only with proper quotation of the source.

Proceedings of the
4th International Conference on Road and Rail Infrastructures – CETRA 2016
23–25 May 2016, Šibenik, Croatia

Road and Rail Infrastructure IV

EDITOR

Stjepan Lakušić
Department of Transportation
Faculty of Civil Engineering
University of Zagreb
Zagreb, Croatia

CETRA²⁰¹⁶

4th International Conference on Road and Rail Infrastructure

23–25 May 2016, Šibenik, Croatia

ORGANISATION

CHAIRMEN

Prof. Stjepan Lakušić, University of Zagreb, Faculty of Civil Engineering
Prof. emer. Željko Korlaet, University of Zagreb, Faculty of Civil Engineering

ORGANIZING COMMITTEE

Prof. Stjepan Lakušić	Assist. Prof. Maja Ahac	All members of CETRA 2016 Conference Organizing Committee are professors and assistants of the Department of Transportation, Faculty of Civil Engineering at University of Zagreb.
Prof. emer. Željko Korlaet	Ivo Haladin, PhD	
Prof. Vesna Dragčević	Josipa Domitrović, PhD	
Prof. Tatjana Rukavina	Tamara Džambas	
Assist. Prof. Ivica Stančerić	Viktorija Grgić	
Assist. Prof. Saša Ahac	Šime Bezina	

INTERNATIONAL ACADEMIC SCIENTIFIC COMMITTEE

Davor Brčić, University of Zagreb
Dražen Cvitanić, University of Split
Sanja Dimter, Josip Juraj Strossmayer University of Osijek
Aleksandra Deluka Tibljaš, University of Rijeka
Vesna Dragčević, University of Zagreb
Rudolf Eger, RheinMain University
Makoto Fujii, Kanazawa University
Laszlo Gaspar, Institute for Transport Sciences (KTI)
Kenneth Gavin, University College Dublin
Nenad Gucunski, Rutgers University
Libor Izvolt, University of Zilina
Lajos Kisgyörgy, Budapest University of Technology and Economics
Stasa Jovanovic, University of Novi Sad
Željko Korlaet, University of Zagreb
Meho Saša Kovačević, University of Zagreb
Zoran Krakutovski, Ss. Cyril and Methodius University in Skopje
Stjepan Lakušić, University of Zagreb
Dirk Lauwers, Ghent University
Dragana Macura, University of Belgrade
Janusz Madejski, Silesian University of Technology
Goran Mladenović, University of Belgrade
Tomislav Josip Mlinarić, University of Zagreb
Nencho Nenov, University of Transport in Sofia
Mladen Nikšić, University of Zagreb
Dunja Perić, Kansas State University
Otto Plašek, Brno University of Technology
Carmen Racanel, Technological University of Civil Engineering Bucharest
Tatjana Rukavina, University of Zagreb
Andreas Schoebel, Vienna University of Technology
Adam Szeląg, Warsaw University of Technology
Francesca La Torre, University of Florence
Audrius Vaitkus, Vilnius Gediminas Technical University



GEOMETRIC DESIGN OF TURBO ROUNDABOUTS ACCORDING TO CROATIAN AND DUTCH GUIDELINES

Tamara Džambas, Saša Ahac, Vesna Dragčević

University of Zagreb, Faculty of Civil Engineering, Dpt. of Transportation, Croatia

Abstract

Turbo roundabout is a specific kind of multilane roundabout with spiral circulatory roadway and physical separation of traffic lanes. This particular roundabout layout was developed in the Netherlands in the late nineties of the last century with the aim of solving capacity and safety problems that occur in standard multilane roundabouts. In this paper geometric design of turbo roundabouts is analysed. Comparative analysis of turbo roundabout design procedures described in the latest Croatian and source Dutch guidelines is made, modifications of Croatian turbo roundabout in regard to Dutch layout are presented, and advantages and disadvantages of both design procedures are discussed.

Keywords: turbo roundabouts, geometric design, Croatian guidelines, Dutch guidelines, comparative analysis, traffic safety

1 Introduction

Because of greater traffic safety and greater capacity in respect to classic intersections, in the last two decades roundabouts became a common design choice for at-grade junction planning [1]. However, experience has shown that roundabouts with more than one traffic lane on the circulatory roadway and intersection approaches have poor traffic safety, and that practical capacity of such roundabouts is often lower than predicted [2]. The reasons for this are high driving speeds and a large number of potential conflicts at roundabout multilane entrances, exits and circulatory roadway [3]. In the past few years road designers are trying to solve these problems by introducing new roundabout layouts [4]. One such layout, which is increasingly used in design of new and reconstruction of existing roundabouts, is turbo roundabout. According to data on web page of Dirk de Baan, 408 turbo roundabouts were constructed worldwide to date, and most of them are located in the Netherlands, country where this particular roundabout was developed [5].

First guidelines for turbo roundabout application and design were published by a Dutch Information and Technology Platform CROW in 2008 [6]. At that time, Netherlands had 70 roundabouts of this kind. Soon after, a number of European countries began to develop their own regulations for the design of turbo roundabout (adjusted to their driving standards and local conditions) and to use turbo roundabouts in their engineering practice [4]. One of the most recent regulations on turbo roundabouts are Croatian guidelines [7]. Novelties in turbo roundabout geometric design introduced in these new Croatian guidelines, with regard to its source Dutch layout, are described below.

2 Turbo roundabout design procedures

According to Dutch [6] and Croatian guidelines [7], geometric design of turbo roundabouts can be carried out through the following steps: (1) selecting one of the available roundabout types; (2) defining a relevant design vehicle; (3) creating one of given turbo block templates with predetermined dimensions; (4) designing the remaining turbo roundabout elements; (5) conducting design vehicle horizontal swept path and fastest path vehicle speed analyses.

2.1 Turbo roundabout types

According to Dutch guidelines [6], seven basic types of turbo roundabouts can be constructed considering the planned traffic volume and capacity distribution on roundabout approaches (Fig. 1):

- Egg, Basic turbo, Knee, Spiral and Stretched-knee roundabout are recommended forms when one of traffic flows is predominant;
- Rotor and Star roundabout are recommended forms in case of equal traffic volumes on all approach legs.

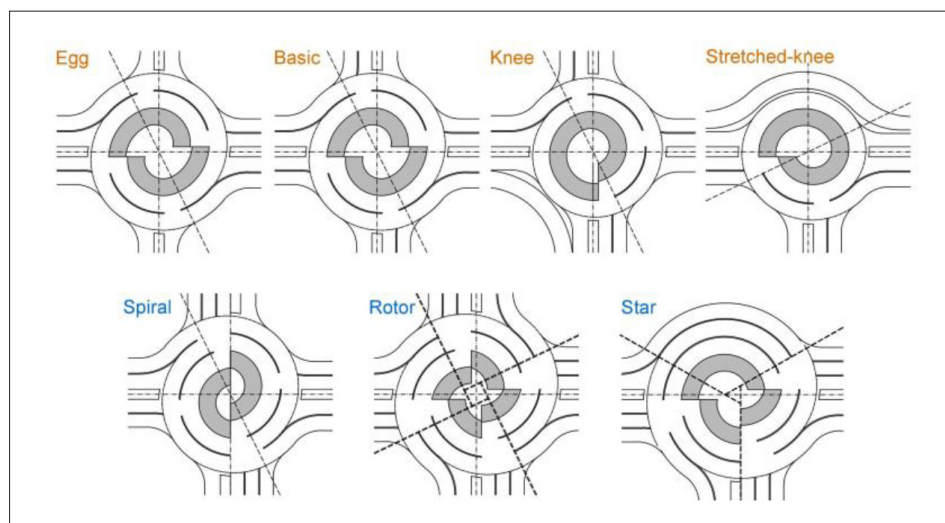

Figure 1 Four leg and three leg turbo roundabout variants [6]

In Croatian guidelines [7], reduced number of aforementioned roundabout forms is given. Those forms are: Egg, Basic, Knee and Stretched-Knee roundabout. It can be noticed that all forms given in this document belong to a group of roundabouts recommended for use in a case of one dominant traffic flow. Considering the fact that [7] recommends the usage of turbo roundabouts when existing two-lane roundabouts have poor traffic safety and low capacity, and the fact that existing two-lane roundabouts often have evenly spread traffic volumes on all approach legs, it would be advisable that variants where traffic demand is evenly spread on all approach legs are also included.

2.2 Design vehicles

In Dutch guidelines [6] relevant design vehicle for turbo roundabout planning is a two-axle truck with a three-axle semitrailer (Fig. 2). As reported in Sweden [8], this is the most used vehicle combination in Europe. In Appendix D of Croatian guidelines for the design of ro-

undabouts [9], relevant design vehicle on Croatian state roads is a three-axle truck with a three-axle semitrailer (Fig. 2). According to [8], these three-axle tractors are necessary to avoid overloading of the driving axle due to the high transport loads.

The application of three-axle truck with a three-axle semitrailer as a design vehicle in Croatian design practise is questionable for the following reasons: this vehicle combination was chosen on the basis of report from Sweden [8], and vehicle fleet in Sweden significantly differs from vehicle fleet in Croatia; analysis of the catalogues and web pages of manufacturers that are common on Croatian market showed three-axle trucks with a three-axle semitrailers are extremely rare in Croatia, and that two-axle trucks with a three-axle semitrailers are far more frequent.

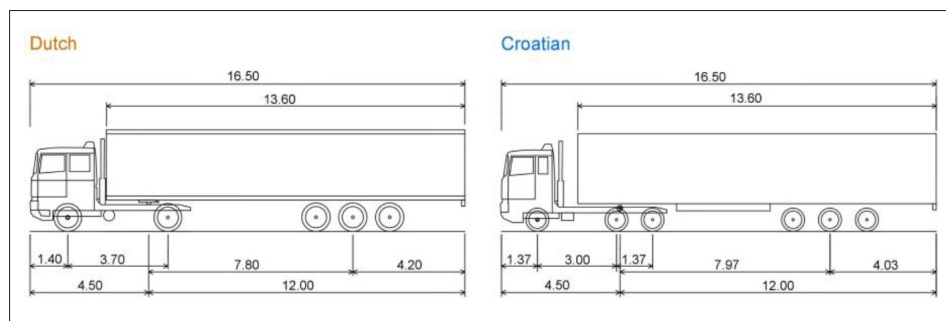

Figure 2 Dutch and Croatian design vehicles

Croatian design vehicle width is 2.50 m [9], while the width of the Dutch design vehicle amounts to 2.55 m [6], which is the actual width of trucks with semitrailers in the catalogues of the vehicle manufacturers that are frequent on the European market, and the maximum allowed width of motor vehicles and trailers according to Committee Directive 2002/7/EC (96/53/EC) [10]. Considering the above, and the fact that larger vehicle width leads to more stringent requirements in terms of swept path analysis, it would be advisable that the width of Croatian design vehicle is also set to 2.55 m.

Along with the vehicle width, parameters that influence vehicle swept path are the distance from vehicle front to kingpin (on both analysed vehicles this distance is 4.50 m), and length of the semitrailer wheelbase (on Croatian design vehicle this length amounts 7.97 m, and on Dutch design vehicle 7.80 m) (Fig 2). Because of longer semitrailer wheelbase Croatian design vehicle occupies a greater area during the swept path analysis.

2.3 Turbo block templates

A turbo block is an auxiliary construction used in the design of turbo roundabout spiral circulatory roadway [3]. Turbo block for common Dutch and Croatian roundabout variants (Egg, Basic turbo, Knee and Stretched-Knee roundabout) consist of four pairs of circular arcs with consecutive larger radii (R_1, R_2, R_3, R_4), which overlap on the line called a translation axis (Fig. 3).

Both Dutch [6] and Croatian [7] guidelines provide various turbo block templates with pre-determined dimensions, depending on the size of a roundabout radius. As shown in Table 1, most of the dimensions of turbo block templates given in those two documents differ for 5 cm. This difference arises from different widths of outer marginal strips on circulatory roadway: in [6] these strips are 45 cm wide, and in [7] 50 cm (Fig. 3). Widths of inner marginal strips, lane dividers and circulatory lanes between the marginal strips are equal.

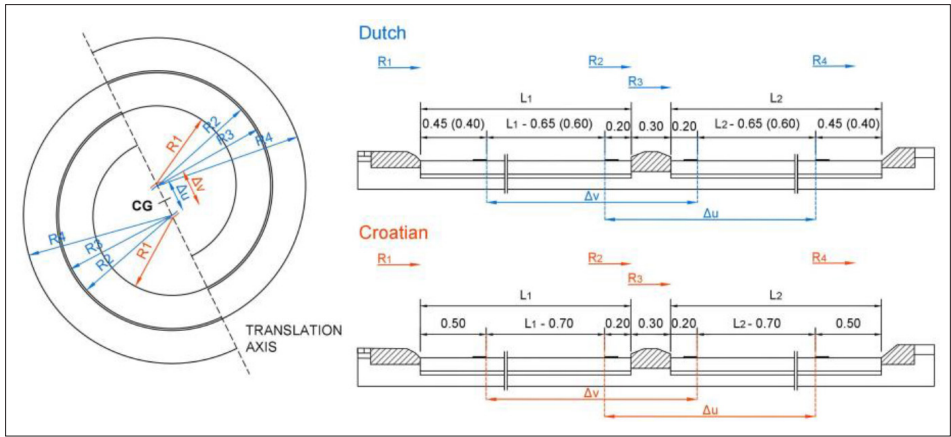

Figure 3 Turbo block elements for common Dutch and Croatian roundabout variants

Table 1 Dimensions of Dutch (NLD) [6] and Croatian (CRO) [7] turbo block templates

Element	Turbo roundabout template							
	Mini		Regular		Medium		Large	
	NLD	CRO	NLD	CRO	NLD	CRO	NLD	CRO
R_1 [m]	10.50	10.45	12.00		15.00	14.95	20.00	19.95
R_2 [m]	15.85		17.15		20.00		24.90	
R_3 [m]	16.15		17.45		20.30		25.20	
R_4 [m]	21.15	21.20	22.45		25.20	25.25	29.90	29.95
L_1 [m]	5.35	5.40	5.15		5.00	5.05	4.90	4.95
L_2 [m]	5.00	5.05	5.00		4.90	4.95	4.70	4.75
Δv [m]	5.75		5.35	5.30	5.15		5.15	
Δu [m]	5.05		5.05	5.00	4.95		4.75	

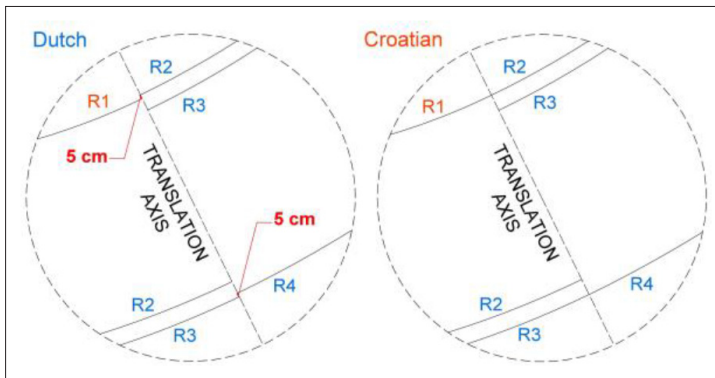

Figure 4 Circular arc shifts [6] and overlapping [7] on translation axis

As shown on Fig. 4, in turbo block templates given in Dutch guidelines [6] circular arcs at one side of the translation axis are not entirely overlapping with circular arcs at the other side of the translation axis: in these templates 5 cm shift of circular arcs exists. In Croatian guidelines [7] this shift is eliminated by application of 5 cm wider outer marginal strips i.e. by

application of different circular arc radii and different radii centres on translation axis. This novelty introduced in Croatian guidelines is very notable, because the discrepancy of circular arcs, which occurs in Dutch regulations, may confuse the designer and lead to incorrect spiral circulatory roadway design.

2.4 Remaining turbo roundabout elements

After creating a turbo block, remaining turbo roundabout elements can be designed: central island, approaches, and raised mountable lane dividers. Turbo roundabout central island consists of traversable apron and non-traversable central part (Fig. 5). Guidelines considered in this paper define these elements in a different manner:

- In Dutch guidelines [6], non-traversable part of central island is “used for placing traffic signs that are cutting the view of the horizon in direction of travel”, and traversable apron is a “surface which enables passage of vehicles longer than 22 m through the inner circulatory lane”. According to this document, the beginning of traversable apron can be designed as flat or spiral. However, the application of flat beginning is recommended, because the spiral one is often ambiguous to the drivers that are approaching roundabout entrance, and it consequently leads to the conflict at roundabout circulatory roadway.
- In Croatian guidelines [7] non-traversable part of central island is defined as a “redundant roundabout space”, and traversable apron is a “surface where special emergency vehicles and regular vehicles in case of emergency can stop”. In this document all roundabout examples shown on figures have traversable apron with spiral beginning, and additional instructions on their design are not given in the text.

Despite the fact that non-traversable part of central island is not directly linked to traffic operations, the guidelines should emphasize that the design of this area of the central island has a great influence on roundabout traffic safety [11]. Also, according to [3], traversable apron usually serves for traffic operations, and not for emergency stops. It can be concluded that the definitions of central island elements placed by Dutch guidelines [6] are more appropriate: in these guidelines the designer is warned about disadvantages of application of traversable apron with spiral beginning, the importance of central island and the proper use of traversable apron.

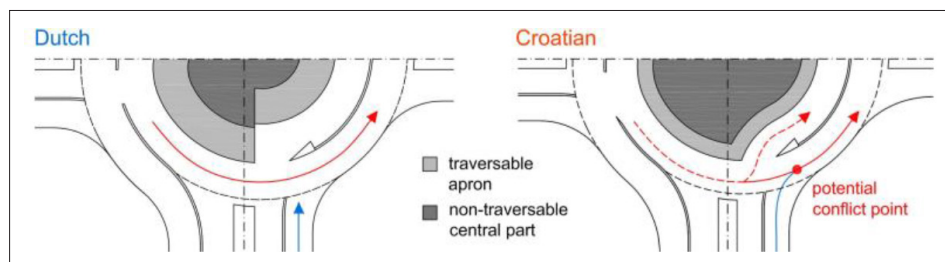

Figure 5 Turbo roundabout central island

Dutch guidelines [6] provide following directions for turbo roundabout approach leg positioning: “turbo roundabout approaches should be aligned at right angles to the circulatory roadway, and because of the rideability of long vehicles these angles should amount 90° ”. In Croatian guidelines [7] detail guidelines on approach leg positioning are not provided. It should be noted that approaches aligned at 90° angles are often difficult to plan, especially in a case of reconstruction of existing intersections located at sites with significant spatial limitations. Considering the above, other possible alignments of turbo roundabout approaches in future studies should be examined: non-radial, curvilinear etc.

Guidelines presented in this paper recommend the use of raised mountable lane dividers – important turbo roundabout element which prevents conflicts on roundabout exits and circulatory roadway, reduces driving speed, and increases capacity and traffic safety [2-3]. It should be noted that these dividers hinder the maintenance and snow removal process, and represent a dangerous obstacle for motorcyclists [12], which is the main reason why opinions about their application are still divided.

2.5 Performance checks

After designing a turbo roundabout, design vehicle horizontal swept path and fastest path vehicle speed analyses must be carried out [6, 7]. If analyses show that applied roundabout elements do not fulfil both swept path and fastest path vehicle speed requirements, redesign of roundabout elements is required.

According to Croatian guidelines [7], “when conducting a critical turning movement the design vehicle must not track over the traversable central apron, or the 30 cm wide raised mountable lane dividers placed between the circulatory lanes, and it can track over the traversable beginning of raised mountable lane divider”. In Dutch guidelines [6], such behaviour is recommended, but not mandatory. More stringent swept path requirements set by Croatian regulations are favourable from the aspect of design vehicle’s driving comfort and therefore should always be respected. This is especially important if relevant design vehicle on proposed turbo roundabout location is a long passenger vehicle.

Dutch [6] and Croatian guidelines [7] do not provide detailed instructions on assigning input parameters for the swept path testing procedure; they only define values of entry path radius. Those procedures can therefore lead to oversized and undersized roundabout solutions: the designer can conclude that chosen roundabout elements are satisfactory if they accommodate the design vehicle swept path in any manner – with lack or extra space for unobstructed passage. Besides that, minimum clearances between the outside edges of the design vehicle’s tire track and the edges of the roadway should always be assigned, because they are necessary for a long vehicle driver to maintain driving direction [13].

Both guidelines [6, 7] are providing same directions for turbo roundabout fastest path vehicle speed analysis procedure: (1) analysis should be carried out for through movement, right turn from the outer entry lane and right turn from the inner entry lane; (2) fastest paths should always be assigned in respect to potential points of impact and distanced from them for 1 m; (3) fastest path vehicle speed should amount between 37 and 40 km/h [6], i.e. 35 and 37 km/h [7]. Minimum value for this speed, which is in direct correlation with design vehicles’ driving comfort, is not recommended.

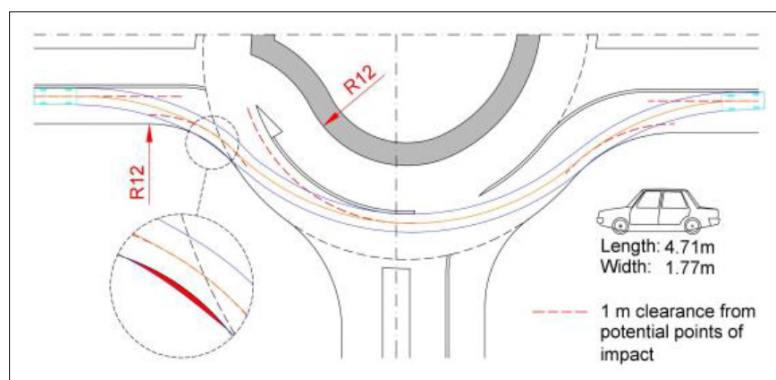

Figure 6 Fastest path vehicle speed analysis

Simple swept path analysis carried out on a standard turbo roundabout of regular size with a passenger car from Dutch regulations [14] showed that 1 m clearance does not always ensure unhindered passage of a passenger car: while driving straight through a turbo roundabout vehicle was tracking over the outer edges of the roadway (Fig. 6). Considering the above, larger minimum clearances should be applied.

3 Conclusion

Analysed Croatian and Dutch guidelines for the design of turbo roundabouts differ in the following: number of turbo roundabout variants, information about relevant design vehicles, dimensions of certain turbo block and cross-section elements, definition of particular roundabout elements, and input parameters in roundabout performance checks. These differences are expected due to the fact that local conditions in Croatia and Netherlands are different, and the fact that at the time when Croatian guidelines were in developing phases some new findings about turbo roundabouts were available (new dimensions of turbo block templates, more stringent swept path requirements which lead to higher driving comfort).

Despite the previous differences, turbo roundabout planning procedures described in Croatian and Dutch guidelines are very similar: firstly the initial roundabout scheme is designed, and then swept path and fastest path vehicle speed analyses are carried out. This design approach therefore greatly depends on the quality of performance checks, and leaves a great freedom to the designer about the decision whether the project solution is acceptable or not. Considering the above, it would be advantageous that these guidelines provide more detail instructions for conducting horizontal swept path and fastest path vehicle speed analysis: a method of assigning the design vehicle path; minimum clearances; lowest recommended speed values for passenger cars.

References

- [1] Omazić, I., Dimter, S., Barišić, I.: Kružna raskrižja – suvremeni način rješavanja prometa u gradovima, e-gfos, 1(1), pp. 54-66, 2010.
- [2] Engelsman, J. C., Uken, M.: Turbo Roundabouts as an Alternative to Two Lane Roundabouts, The challenges of implementing policy?, 26th Southern African Transport Conference (SATC 2007), Pretoria, pp. 581-589, 2007.
- [3] Fortuijn, L. G. H.: Turbo Roundabouts: Design Principles and Safety Performance, Journal of the Transportation Research Board 2096 (2009), pp. 16–24, doi: <http://dx.doi.org/10.3141/2096-03>
- [4] Tollazi, T., Renčelj, M.: Modern and alternative types of roundabouts – state of the art, Sustainable Urban Development, 9th International Conference on Environmental Engineering, Vilnius, pp.1-7, 2014.
- [5] Dirk de Baan, www.dirkdebaan.nl, 09.03.2016.
- [6] Turborotondes, Publication No. 257, CROW, 2008.
- [7] Smjernice za projektiranje kružnih raskrižja sa spiralnim tokom kružnog kolnika na državnim cestama, Hrvatske ceste, 2014.
- [8] Aurell, J., Wadman, T.: Vehicle Combinations Based on the Modular Concept, Report No. 1/2007, Volvo Trucks, 2007.
- [9] Smjernice za projektiranje kružnih raskrižja na državnim cestama, Hrvatske ceste, 2014.
- [10] Directive 2002/7/EC of the European Parliament and of the Council of 18 February 2002 amending Council Directive 96/53/EC laying down for certain road vehicles circulating within the Community the maximum authorised weights in international traffic and the maximum authorised weights in international traffic, OJ L 67.

- [11] Ahac, S., Džambas, T., Dragčević, V.: Sight distance evaluation on suburban single-lane roundabouts, GRAĐEVINAR, 68 (2016) 1, pp. 1-10, doi: 10.14256/JCE.1455.2015
- [12] Brilon, W.: Roundabouts: a State of the Art in Germany, 4th International Conference on Roundabouts, Seattle, pp. 1-16, 2014.
- [13] Džambas, T., Ahac, S., Dragčević, V.: Design of turbo roundabouts based on the rules of design vehicle movement geometry, Journal of Transportation Engineering, 142 (2016) 3, doi: 10.1061/(ASCE)TE.1943-5436.0000850
- [14] Aanbevelingen voor verkeersvoorzieningen binnen de bebouwde kom, Publication No. 723, CROW, 2004.