



CETRA 2018

5th International Conference on Road and Rail Infrastructure
17–19 May 2018, Zadar, Croatia

Road and Rail Infrastructure V

Stjepan Lakušić – EDITOR



Organizer
University of Zagreb
Faculty of Civil Engineering
Department of Transportation



CETRA²⁰¹⁸

5th International Conference on Road and Rail Infrastructure

17–19 May 2018, Zadar, Croatia

TITLE

Road and Rail Infrastructure V, Proceedings of the Conference CETRA 2018

EDITED BY

Stjepan Lakušić

ISSN

1848-9850

ISBN

978-953-8168-25-3

DOI

10.5592/CO/CETRA.2018

PUBLISHED BY

Department of Transportation

Faculty of Civil Engineering

University of Zagreb

Kačićeva 26, 10000 Zagreb, Croatia

DESIGN, LAYOUT & COVER PAGE

minimum d.o.o.

Marko Uremović · Matej Korlaet

PRINTED IN ZAGREB, CROATIA BY

“Tiskara Zelina”, May 2018

COPIES

500

Zagreb, May 2018.

Although all care was taken to ensure the integrity and quality of the publication and the information herein, no responsibility is assumed by the publisher, the editor and authors for any damages to property or persons as a result of operation or use of this publication or use the information's, instructions or ideas contained in the material herein.

The papers published in the Proceedings express the opinion of the authors, who also are responsible for their content. Reproduction or transmission of full papers is allowed only with written permission of the Publisher. Short parts may be reproduced only with proper quotation of the source.

Proceedings of the
5th International Conference on Road and Rail Infrastructures – CETRA 2018
17–19 May 2018, Zadar, Croatia

Road and Rail Infrastructure V

EDITOR

Stjepan Lakušić
Department of Transportation
Faculty of Civil Engineering
University of Zagreb
Zagreb, Croatia

ORGANISATION

CHAIRMEN

Prof. Stjepan Lakušić, University of Zagreb, Faculty of Civil Engineering
Prof. emer. Željko Korlaet, University of Zagreb, Faculty of Civil Engineering

ORGANIZING COMMITTEE

Prof. Stjepan Lakušić
Prof. emer. Željko Korlaet
Prof. Vesna Dragčević
Prof. Tatjana Rukavina
Assist. Prof. Ivica Stančerić
Assist. Prof. Maja Ahac
Assist. Prof. Saša Ahac
Assist. Prof. Ivo Haladin
Assist. Prof. Josipa Domitrović
Tamara Džambas
Viktorija Grgić
Šime Bezina
Katarina Vranešić
Željko Stepan

Prof. Rudolf Eger
Prof. Kenneth Gavin
Prof. Janusz Madejski
Prof. Nencho Nenov
Prof. Andrei Petriaev
Prof. Otto Plašek
Assist. Prof. Andreas Schoebel
Prof. Adam Szeląg
Brendan Halleman

INTERNATIONAL ACADEMIC SCIENTIFIC COMMITTEE

Stjepan Lakušić, University of Zagreb, president
Borna Abramović, University of Zagreb
Maja Ahac, University of Zagreb
Saša Ahac, University of Zagreb
Darko Babić, University of Zagreb
Danijela Barić, University of Zagreb
Davor Brčić, University of Zagreb
Domagoj Damjanović, University of Zagreb
Sanja Dimter, J. J. Strossmayer University of Osijek
Aleksandra Deluka Tibljaš, University of Rijeka
Josipa Domitrović, University of Zagreb
Vesna Dragčević, University of Zagreb
Rudolf Eger, RheinMain Univ. of App. Sciences, Wiesbaden
Adelino Ferreira, University of Coimbra
Makoto Fujii, Kanazawa University
Laszlo Gaspar, Széchenyi István University in Győr
Kenneth Gavin, Delft University of Technology
Nenad Gucunski, Rutgers University
Ivo Haladin, University of Zagreb
Staša Jovanović, University of Novi Sad
Lajos Kisgyörgy, Budapest Univ. of Tech. and Economics

Anastasia Konon, St. Petersburg State Transport Univ.
Željko Korlaet, University of Zagreb
Meho Saša Kovačević, University of Zagreb
Zoran Krakutovski, Ss. Cyril and Methodius Univ. in Skopje
Dirk Lauwers, Ghent University
Janusz Madejski, Silesian University of Technology
Goran Mladenović, University of Belgrade
Tomislav Josip Mlinarić, University of Zagreb
Nencho Nenov, University of Transport in Sofia
Mladen Nikšić, University of Zagreb
Andrei Petriaev, St. Petersburg State Transport University
Otto Plašek, Brno University of Technology
Mauricio Pradena, University of Concepcion
Carmen Racanel, Tech. Univ. of Civil Eng. Bucharest
Tatjana Rukavina, University of Zagreb
Andreas Schoebel, Vienna University of Technology
Ivica Stančerić, University of Zagreb
Adam Szeląg, Warsaw University of Technology
Marjan Tušar, National Institute of Chemistry, Ljubljana
Audrius Vaitkus, Vilnius Gediminas Technical University
Andrei Zaitsev, Russian University of transport, Moscow



FATIGUE LIFE LOSSES OF RAILWAY CONCRETE SLEEPERS DUE TO SURFACE ABRASIONS

Ruilin You², Dan Li¹, Sakdirat Kaewunruen¹

¹ *The University of Birmingham, Birmingham, United Kingdom*

² *China Academy of Railway Sciences, Beijing, China*

Abstract

Railway concrete sleepers are one of the most significant components of ballasted track. The failure of a concrete sleeper is considered to be the process of accumulated damage due to repeated loads over a long period of time. The fatigue life of concrete sleepers is a concerned question of operation and maintenance departments of railway line. Despite the importance of the effects of wheel-rail interaction loads in the reduction of the life cycle and operation time of concrete sleepers has been realized, at present, there is no systematic procedure for the service life analysis of concrete sleepers under repeated loads. Based on the damage accumulation method, this paper presents a fatigue life assessment method for a prestressed concrete sleeper, and researches the fatigue life losses caused from surface abrasions. Surface abrasion is one of the most common problems of the concrete sleepers will reduce its resistance capability, and then influence its fatigue life. The outcome of this study can be used to evaluate the service performance of the abrasive concrete sleeper and improve the rail track maintenance and inspection criteria.

Keywords: railway infrastructure, prestressed concrete sleeper, surface abrasion, fatigue, time-dependence

1 Introduction

Development of railway transportation system is significant and continuously around world. Railway transportation plays a vital role for economy. Railway is also the safest transportation which gives highly enjoyable ride for both of passengers or freights. Conventional ballasted railway structure consists of superstructure and substructure. The superstructure includes rails, rail pads, fastening system and sleepers. The substructure consists of ballast, sub-ballast and formation. Railway sleeper (also called rail tie in North America) is very important component in rail track structure. The main functions of sleeper are [1]:

- 1) Support the rails and maintain the track gauge.
- 2) Transfer and distribute vertical loads from superstructure to substructure.
- 3) Withstand vertical and longitudinal movement of rails.

Railway sleepers can be manufactured by timber, steel, concrete and any other engineered materials. Nowadays, prestressed concrete is the most common type used in sleepers around the world, which it has good structural performance and low cost in maintenance. However, railway sleepers experience millions repeated loading in service life and the progress of cracking depends on cyclic behaviour which caused by the wheel-rail interaction force. Nowadays, the permissible stress (also called ‘allowable stress’) method is utilised for concrete sleeper design which the dynamic load is not considered in design accurately [2, 3]. For example, in Japan

concrete sleepers cracks happen frequently have been found in high quality track under severe loading environments [4]. Therefore, the fatigue limit state should be considered in design process. Amount of experiments about dynamic influence on prestressed concrete sleepers has been conducted in University of Wollongong, the crack damage due to fatigue were investigated [5-8]. This research aims at providing a principle understanding of cyclic behaviour of railway concrete sleepers. This study also presents prediction method of cyclic behaviour on railway concrete sleepers. The outcome of this research will provide appropriate design principle for the concrete sleepers and it will help improve track maintenance and inspection system.

2 Fatigue life and predict method

2.1 Structural performance

Fatigue is a time-dependent behaviour where the damage due to repeat load will be accumulated. The fatigue damage in railway sleeper generated from wheel-rail interaction and it is determined by wheel-rail stress. The damage is random but the performance of railway concrete sleeper will decrease due to material degradation. The service life of railway concrete is usually more than 50 years. The life cycle performance of railway concrete sleeper is shown in Figure 1. $R(t)$ is the resistance of concrete sleeper and $S(t)$ is the effect of cyclic roads. The performance graph is presented by probability distribution function. It can be considered as probability of sleeper failure when $R(t) < S(t)$ in risk measurement. From the curve, the probability of sleeper failure keeps increasing with time.

2.2 Fatigue life time prediction

The Miner's Rule is usually used in predicting accumulated damage in many design codes [9, 10]. The damage accumulation method will be used to predict fatigue life of railway concrete sleeper in this research.

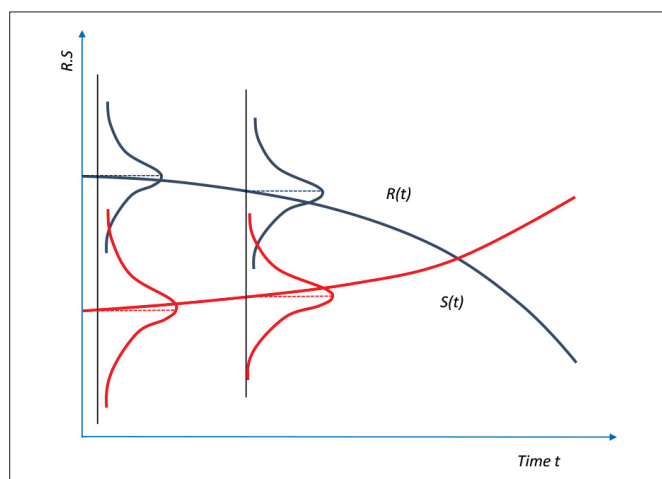

Figure 1 Life cycle performance of concrete sleeper

The cumulative damage index $\sum Di$ in multi-cycles with variable amplitudes can be calculated by:

$$\sum Di = \sum_i \frac{n(\Delta\sigma_i)}{N(\Delta\sigma_i)} \quad (1)$$

Where $n(\Delta\sigma_i)$ is the applied number of cycles for a stress range $\Delta\sigma_i$; $N(\Delta\sigma_i)$ is the resisting number of cycles for a stress range $\Delta\sigma_i$.

This method is used to predict fatigue life under constant amplitude cycle loads and it is based on damage accumulation method. The corresponding S-N curve shown Figure 2 is utilised to determine the maximum applied number of cycles for single stress amplitude.

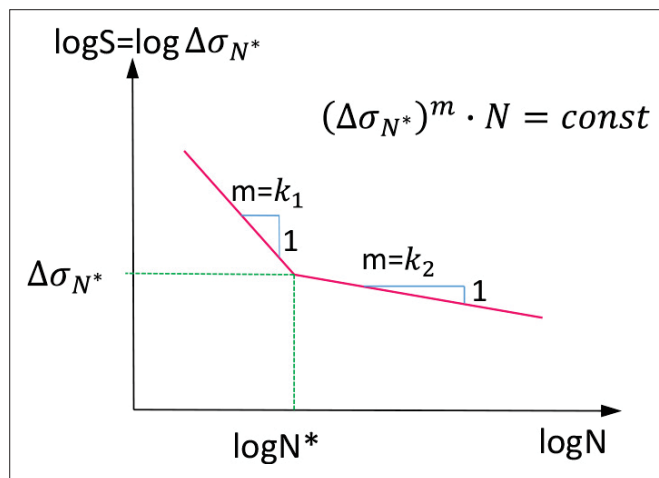

Figure 2 the corresponding S-N curve

Therefore, the failure cycles of the prestressing steel under a constant amplitude cyclic load can be given by:

$$\text{If } \Delta\sigma > \Delta\sigma_{N^*}, \log N_f = \log N^* - k_1 [\log(\Delta\sigma) - \log(\Delta\sigma_{N^*})] \quad (2)$$

$$\text{If } \Delta\sigma \leq \Delta\sigma_{N^*}, \log N_f = \log N^* + k_2 [\log(\Delta\sigma_{N^*}) - \log(\Delta\sigma)] \quad (3)$$

Where:

$\Delta\sigma$ is the stress range in the prestressing steel;

$\Delta\sigma_{N^*}$ is the stress range at N^* cycles which shown in Table 1.

Table 1 Parameters of S-N curves for prestressing steel

S-N curve of pre-stressing steel used for	Stress exponent		$\Delta\sigma_{N^*}$ [MPa] at N^* cycles	
	N^*	k^1		k^2
Pre-tensioning	10^6	5	9	185

$\Delta\sigma_{N^*}$ is the stress range obtained from a characteristic fatigue strength function.

Loo et al. (2010) suggested that the mean value of $\Delta\sigma_{N^*}$ for reinforced steel is 290 MPa. Parvez and Foster (2015) stated the mean value of $\Delta\sigma_{N^*}$ is 300 MPa for prestressing steel. Therefore, in this study the $\Delta\sigma_{N^*}$ takes 300 MPa.

2.3 Fatigue load

To determine the fatigue load is the first step to investigate the cyclic behaviour of railway concrete sleepers. The fatigue loads are generated from wheel-rail interaction which influenced by train speed, axle loads, curve radius of track, track quality and environments etc. wheel-rail interaction force is various even in same rail line. Therefore, it's hardly to obtain accurate fatigue load of railway sleeper through whole service life. Some researchers use the wheel dynamic load detector to obtain the wheel-rail interaction force in the railway (at least 1 year in period). The data obtained from site which can be used to generate numerical

modelling and predict the fatigue load. In 2004, the impact force was tested by Queensland University of Technology in two different sites. The dynamic wheel-rail interaction force statistical data is shown in Figure 3.

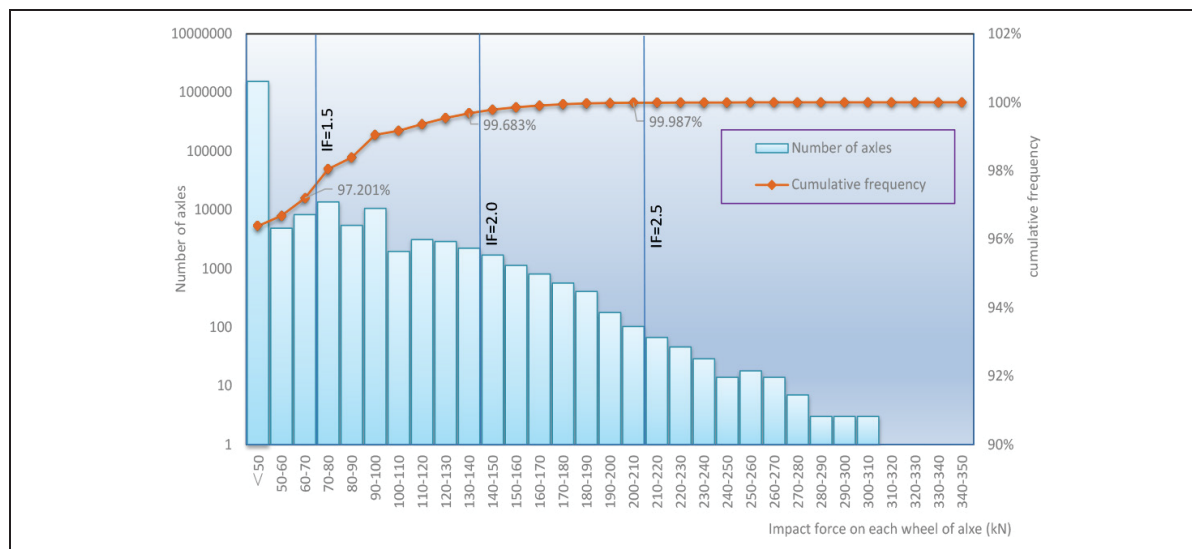

Figure 3 Typical impact force statistical data on track

Most of impact forces are not more than 70 kN and the cumulative frequency of these data are 97.201%. Impact loads more than 210 kN, the frequency of these extremely large impact load is less than 0.0013%, which could be led by imperfection of geometry of wheel or rail.

2.4 Bending moment

The bending moments of railway sleepers are caused by dynamic load on the railseat (railseat load) which affected by wheel load, impact factor and distribution factor. Railseat load can be determined by:

$$R = P \times DF \times IF \quad (4)$$

Where: P is the static load, DF is distribution factor, IF is impact factor. Maximum positive bending moment at railseat:

$$M_{RS+} = \frac{R}{8}(L - g) \quad (5)$$

Maximum negative bending moment at railseat:

$$M_{RS-} = 0.67M_{RS+} \quad (6)$$

Maximum negative bending moment at centre:

$$M_{C-} = \frac{R}{4}(2g - L) \quad (7)$$

Maximum positive bending moment at centre:

$$M_{C+} = 0.05R(L - g) \quad (8)$$

3 Section and material properties

The detail of railway sleeper is shown on Figure 4. The material properties of railway sleeper is shown in Table 2.

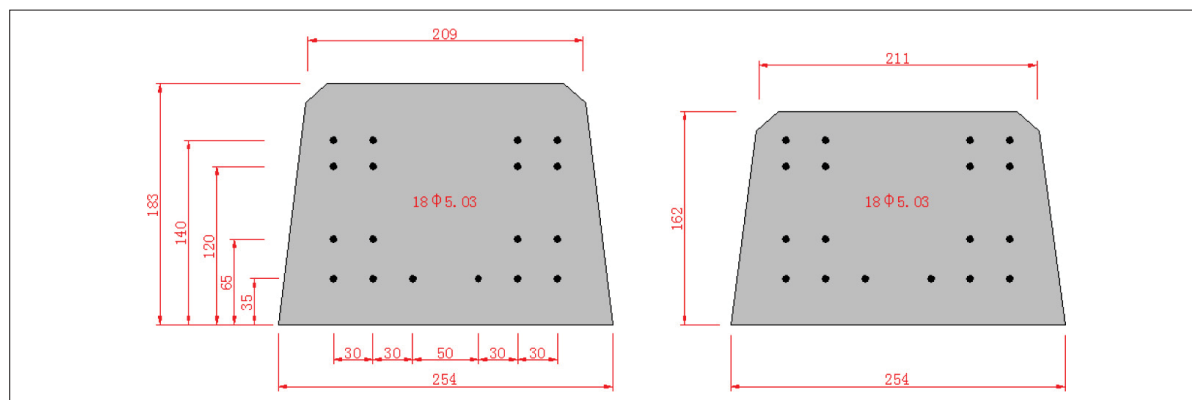

Figure 4 Railseat and centre section of sleeper

Table 2 Material properties of railway sleeper

Materials properties		Symbol	Value
Concrete	mean compressive strength mean compressive strength	f_{cm}	58 MPa
	Flexural tensile strength	f_{cf}	4.5 MPa
	Modulus of elasticity	E_c	36.0 GPa
Prestressed wire	Ultimate tensile strength	f_{pb}	1950 MPa
	Yield strength	f_{py}	1620 MPa
	Modulus of elasticity	E_s	200 GPa

4 Remaining fatigue life calculation

The failure analysis of fatigue of concrete sleeper can be divided into two stages. In first stage, there is no crack appeared in this stage. The relationship between stress and stain is assumed as linear for both of concrete and steel. The critical cracking moment can be calculated:

$$M_{cr} = I_t \cdot \frac{\sigma_{cf}^b + f_{cf}}{y_t} \quad (9)$$

$$\sigma_{cf}^b = \frac{nA_{ps}\sigma_{se}}{A_t} + \frac{nA_{ps}\sigma_{se}e}{I_t} y_t \quad (10)$$

In second stage, the crack happens and the neutral axis of cross-section will change. When the section is fully cracked, the prosperity of the section can be calculated. The distance from the center gravity of the effective transformed area to the top of the compressed area y_{CG} can be calculated by:

$$y_{CG} = \text{root} \left[\begin{array}{l} S_{p_{cl}} - n_e A'_{p4} (h - y_{cg} - d_4) - n_e A'_{p3} (h - y_{cg} - d_3) \\ - n_e A'_{p2} (h - y_{cg} - d_2) - n_e A'_{p1} (h - y_{cg} - d_1) \end{array} \right], y_{cg} \quad (11)$$

Where the S_{pcII} is the first moment about the bottom fibre after cracking, the A'_{pi} is area of the prestress steel in layer i , and d_i is the distance from prestress steel in layer i to the bottom of tension area.

Using transformed area of concrete section A_{cII} , the effective transformed section can be calculated:

$$A_{tII} = A_{cII} + n_e A_p \quad (12)$$

The moment of inertia of the fully cracked section:

$$I_{cr} = I_{c_{cr}} + n_e A'_{p4} (h - y_{cg} - d_4)^2 + n_e A'_{p3} (h - y_{cg} - d_3)^2 + n_e A'_{p2} (h - y_{cg} - d_2)^2 + n_e A'_{p1} (h - y_{cg} - d_1)^2 \quad (13)$$

Effective moment of inertia in the life time:

$$I_{ef} = I_{cr} + (I_t - I_{cr}) \left(\frac{M_{cr}}{M_{max}} \right)^3 \quad (14)$$

Where the I_t is the moment of inertia of transformed section before cracking, M_{cr} is the cracking moment, M_{max} is the maximum bending moment at section under cyclic load.

And then, the tension stresses range in the first layer prestress steel at tension area:

$$\Delta\sigma_{pt1} = n_e \frac{M_{max} - M_{min}}{I_{ef}} (h - y_{cg} - d_1) \quad (15)$$

Where M_{min} is the minimum bending moment at the section under cyclical loads.

5 Results

The damage index of each year (D_i) and accumulated damage (ΣD_i) are calculated and shown in Figure 6. The total cyclic impact between wheel and rail through a sleeper is assumed 1609712 times for a year.

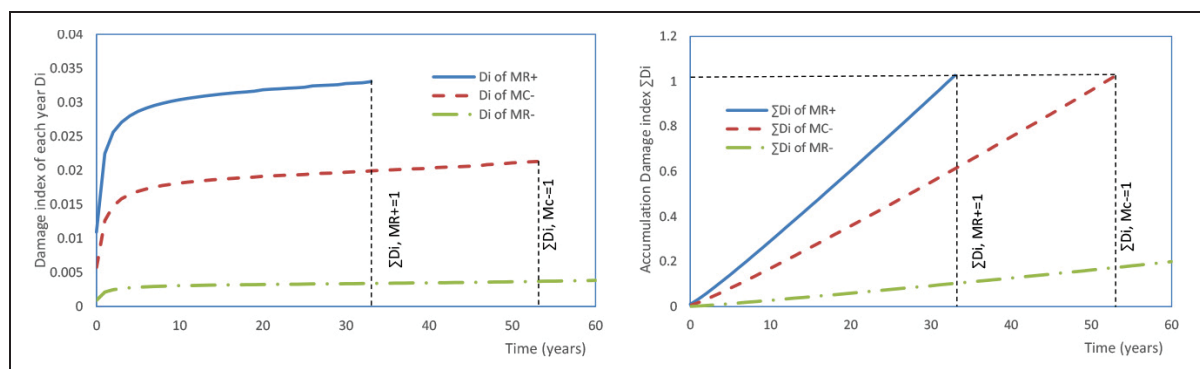

Figure 5 The damage index of each year and accumulated damage with time

From the graph, in early age the damage increases sharply which could be led by loss of prestress. After 2 years in service, the the loss of prestress due to material properties become steady then the damage increases slow. The accumulated damage index shows that the positive bedding moment is about 33 years, which means the fatigue life is 33 years.

6 Conclusion

In this paper, the fatigue life of railway concrete sleepers has been assessed by damage accumulation method. In fatigue life analysis, the fatigue load and material properties are the most important parts to calculate fatigue life of railway sleepers. During the service life, the material properties will be influenced by impact loading and degradation. In long-term, degradation of concrete sleepers become significantly. This research also found more than 99.5% impact loads can't result in positive flexure cracking. The results show that the fatigue failure of railway sleepers at railseat area is determined by the positive bending moment and the fatigue life is around 33 years. At centre area, the fatigue failure is determined by negative bending moment which has 53 years fatigue life.

In different rail lines, the fatigue life can be influence by several factors like material properties, maintenance and manufacture quality etc. This report will improve the concrete sleeper design, maintenance and inspection system.

References

- [1] Li, D., Kaewunruen, S., Robery, P.: Creep and Shrinkage Effects on Railway Prestressed Concrete Sleepers, First International Conference on Rail Transportation – ICRT 2017, Chengdu, China, 2017.
- [2] AS1085.14. Railway track material Part 14: Prestressed concrete sleepers. Australia: Standards Australia; 2003.
- [3] AREMA. AREMA-Manual for Railway Engineering. Chapter 30 Ties. Maryland, American American Railway Engineering and Maintenance-of-Way Association; 2012.
- [4] Wakui, H., Okuda, H.A.: Study on Limit State Design Method for Prestressed Concrete Sleepers. Doboku Gakkai Ronbunshu. 1997; pp. 35-54.
- [5] Kaewunruen, S., Remennikov, A.: Experimental and numerical studies of railway prestressed concrete sleepers under static and impact loads. Civil Computing. 2007;3:25-8.
- [6] Kaewunruen, S., Remennikov, A.M., Murray, M.H.: Introducing a new limit states design concept to railway concrete sleepers: an Australian experience. Frontiers in Materials. 2014;1:8.
- [7] Kaewunruen, S., Remennikov, A.: On the residual energy toughness of prestressed concrete sleepers in railway track structures subjected to repeated impact loads. Electronic Journal of Structural Engineering. 2013;13:41-61.
- [8] Remennikov, A., Murray, M.H., Kaewunruen, S.: Reliability-based conversion of a structural design code for railway prestressed concrete sleepers. Proceedings of the Institution of Mechanical Engineers, Part F: Journal of Rail and Rapid Transit. 2012;226:155-73.
- [9] EN1992-2. Eurocode 2- Design of concrete structures. Part 2: Concrete bridges -Design and detailing rules Brussels European Committee for Standardization; 2005.
- [10] EN1993-1-9. Design of steel structures. Part 1-9: Fatigue Brussels: European Committee for standardization; 2009.
- [11] Loo, K.Y.M.: Fatigue behaviour of CFRP-repaired corroded RC beams [Ph.D]. Sydney, Australia: The University of New South Wales; 2010.
- [12] Parvez, A.: Fatigue behaviour of steel-fibre-reinforced concrete beams and prestressed sleepers [Ph.D]. Australia: The University of New South Wales; 2015.