

DESIGN DEVELOPMENT OF 9.759KM LONG SIX LANE EXTRADOSED BRIDGE PROJECT CROSSING RIVER GANGA IN THE STATE OF BIHAR, INDIA

P. R. Vital Veera, Inki Choi, R. Kasi Viswanath
L&T Construction, Chennai, Tamilnadu, India

Abstract

The paper narrates the purpose of the six Lane highway project linking between north and south zone of Bihar state with 9.759 km long extradosed bridge crossing River Ganga and necessity of adopting extradosed bridge concept for crossing the entire 9.759 km length. Development of structural scheme like bifurcation of the overall bridge into individual blocks, span configuration, type of connection between substructure and superstructure have been articulated. Also necessity to adopt well foundations; design development as per construction methodology; expansion joint with Needle Beam concept; deck segment section finalization have been explained. One of the most critical phase in the project is the junction development over main bridge. Which establishes the connection with the island by ramp structures in the midway of the Bridge. The proposed ramp structures just above the High Flood Level in junction development to facilitate as a rescue shelter during high floods. The paper concludes with benefits and difficulties of extradosed concept is used in this project over traditional balanced cantilever bridges for widen decks to accommodate six lanes of vehicular traffic with both side footpaths.

Keywords: Extradosed Bridge; Well Foundations; Expansion Joint; Bihar.

1 Introduction

Bihar, a state in eastern part of India has the immense potential of industrial growth which needs better connectivity of villages and towns with nearest cities and cities are interlinked with highway and expressways. The government of Bihar initiated a comprehensive plan to develop highways through Bihar State Road Development Corporation Limited (BSRDCL). As a part of this development, BSRDCL has proposed the construction of Six Lane Extradosed Cable Bridge over River Ganga between Kacchi Dargah and Bidupur banks under Engineering, Procurement and Construction (EPC) mode of contract. The total project corridor length of 22.76 km, in which 9.759 km width of Ganga River needs to be crossed by bridging inhabited areas on both sides. The functional requirements of project as per client requirements and site constraints are shown in Table1 and are used for development of concept within these boundary limitations.

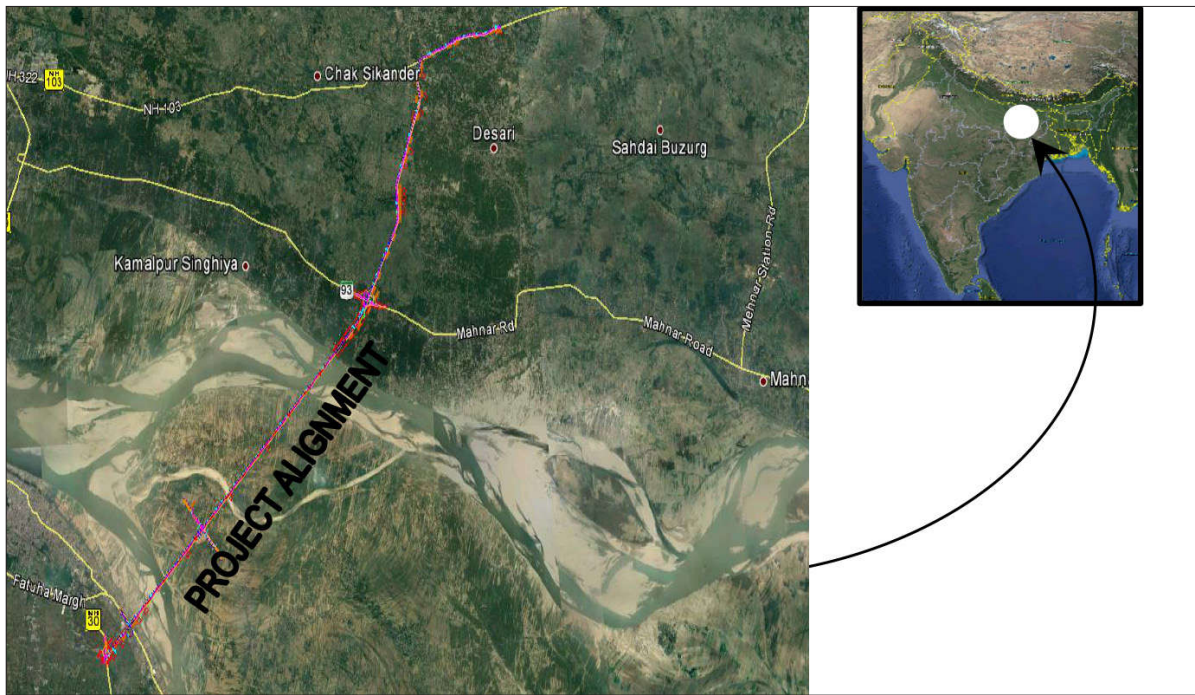

Figure 1 Site Location showing Project Alignment

Table 1 Functional Requirement of the Project

S. No.	Functional Requirements
1	Total Main Bridge Length – 9759 m
2	Total Main Bridge should be Six Lane Carriageway
3	Each Span Navigation Clearance – 100m horizontal and 10 m vertical above HFL
4	All foundations for main bridge should be Well Foundations
5	High Embankments on approaches to Main Bridge should be avoided for height more than 7m and should be replaced with Elevated Viaducts

The width requirements for the main bridge deck also produced in Table 2 as per client requirements and also has to satisfy the provisions as per Indian Standard “IRC SP 87:2013 [2] – Manual of Specifications and Standards for six Laning of Highways through Public Private Partnership”.

Table 2 Carriageway Width of Main Bridge

Description	Dimensions	
Carriageway	2 X 10.5	= 21.0 m
Crash Barrier	2 X 0.45	= 0.90 m
Footpath	2 X 1.50	= 3.00 m
Shy distance + Paved shoulders	4 X 0.50 + 2 X 1.5	= 5.00 m
Railing Kerb	2 X 0.30	= 0.60 m
Median including Crash Barrier	2 X 0.45 + 2.00	= 2.90 m
Total Deck Width	32.4 m	

2 Need of 9759m Long Bridge to Cross River Ganga and Extradosed concept

The project intends to connect Northern Bihar with Patna and to make connection with Island villages. The present perennial channels of Ganga River carry the flow within the width of 2.7 km which keep on meandering in any direction within the both banks of the overall river width i.e. 9.759 km as per study on past 100 years morphology data of River Ganga at this location. With reference to the studies on morphological changes, the main bridge is proposed for the entire 9759 m length to cross River Ganga as a best suitable option at this location.

Ganga River is an important navigation channel in India and termed as National Waterway 01 (NW-01) as per Inland Waterways Authority of India (IWAI). The river needs sufficient navigational clearance as per IWAI, which is 100 m for horizontal clearance and vertical clearance (below soffit of girder) of 10m above navigational HFL for the entire bridge as stated in the Indian Standard IRC-06 [3]. Based on this criteria, three different studies conducted by Client with different superstructure options i.e. PSC Segmental balanced cantilever, Steel Truss and extradosed Stay Cable. By considering the span length requirement to accommodate navigational clearance and six lanes wide deck, the extradosed stay cable bridge emerges out to be a better option based on site constraints. The following points further reiterates the suitability of the extradosed bridge option:

- The precast balanced cantilever concept needs two separate decks with each having three lanes, it is limited by the lifting capacity of erection tackle. It is unfavorable in this project based on construction period and cost.
- Steel Truss can be one of the better options but costs much more compared to prestressed concrete Bridge. Refer Table 3 for preliminary cost estimation.
- Extradosed concept is hybrid design methodology between balanced cantilever & Cable Stayed bridges, where deck segment stiffness can be reduced compared to deck stiffness for balanced cantilever option by introducing stay cables externally.

Table 3 Preliminary Price Comparison for 9756.5m (During Conceptual Stage) [1]

S.No.	Type of Structure	Preliminary Estimated Price (Crores* in INR)
1	Balanced Cantilever Bridge	2598.38
2	Steel Girder Bridge	5443.17
3	Extradosed Bridge	2231.18

* 1 Crore INR = 10,000,000 INR

3 Concept development and design details

Based on the Client's decision and as per the preliminary cost estimation, extradosed bridge concept is adopted in the project. Accordingly 150 m span is considered for main bridge and further optional studies with different span configurations between expansion joints are carried out. Span Configuration Initial optional study as below:

- Option 1: Bearing system with 4 pylons, unit block of 600 m (75+150+150+150+75);
- Option 2: Bearing system with 5 pylons, unit block of 750 m (75+150+150+150+150+75);
- Option 3: Monolithic with 3 pylons, unit block of 450 m (75+150+150+75).

With reference to the above three options, Option-3 is finalized based on technical aspects Long-term/Temperature effects; Pre-camber control; Construction methodology as well as optimization of structural components.

As shown in the Figure. 2, typical unit block with a length of 450 m between both side expansion joints. The connection between superstructure and substructure is made monolithic based on design criteria which helps to ensure stability during construction and also eliminate maintenance for bearings. Seven stay cables on each side of pylon have been used and anchored in the median of deck. Due to stiffness of deck and lesser height of upper pylons, stress variation due to traffic load in stay cable is much lessor than conventional cable stayed bridge and this helps to mitigate the concern regarding fatigue in stay cables. Also the extradosed bridge improves architectural view of the bridge, the aesthetic appearance of Kacchi Dargah Bridge is shown in Figure. 3.

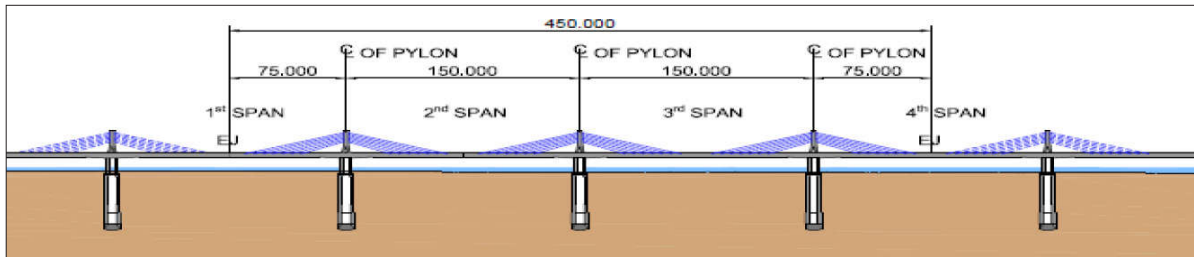

Figure 2 Elevation of the Typical Block



Figure 3 Aesthetic appearance of Extradosed Bridge

3.1 Analysis and Design

The design of extradosed bridge is developed in accordance with IRC bridge design specifications and SETRA recommendations for stay-cable design, testing, and installation. Design speed adopted in the project is 100kmph for main carriageway. Further, construction stage analysis is carried out considering the erection sequence, time dependent material property and changes in boundary conditions. Also detailed FEM analysis using plate model is carried out in order that the load transferring mechanism from the Stay cable to deck and internal strut is clarified.

3.2 Geometry

The extradosed main bridge consists of 22 blocks of two-span continuous having span arrangement of 75 m + 2×150 m + 75 m with three monolithic pylons. Lower pylons are having heights of 18.35m. Double-D type well foundations are adopted based on scour conditions and subsurface soil data. Part of the span loads from superstructure are transferred to foundations

through upper pylons by stay cables on each side of pylons. Depth of box girder is typically 4.0 m and varies up to 5.0 m near to pylon over a length of around 14.5 m on both sides of pylon. As deck width of superstructure is 32.4 m and bridge is located in high seismic area (Zone IV), the weight of the superstructure deck is minimized by providing internal and external struts along with transverse PT in the top slab of the deck. Internal struts at cable anchorage zone is strengthened by internal tendons to transfer the stay force to webs. Typical cross sectional view of precast segmental box girder with internal and external struts are shown in Figure. 4.

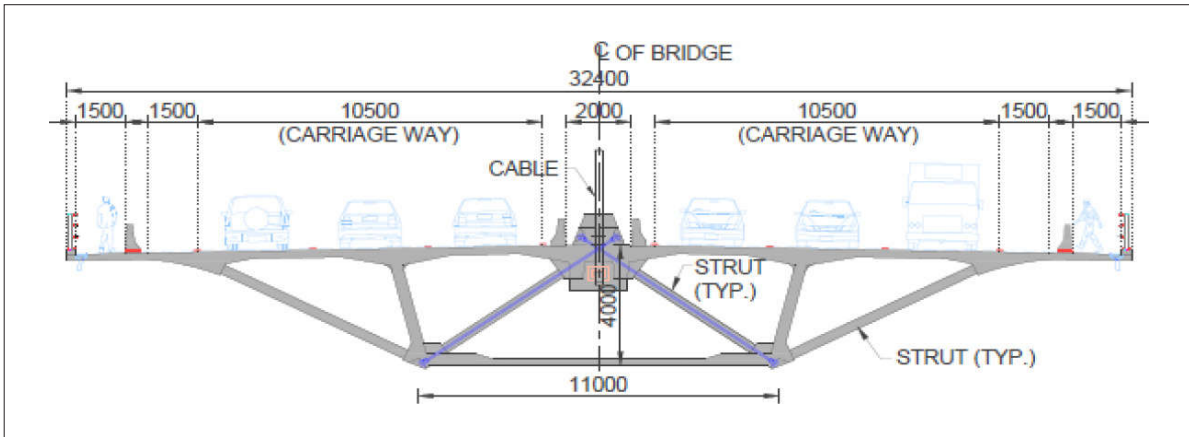

Figure 4 Cross sectional details of Girder

Double leaf reinforced concrete (RC) column is adopted for lower pylon which is connected to the girder as a monolithic connection. The shape of the proposed lower pylon has key merits such as imparting flexibility against thermal or long term displacement thus providing feasible solution to eliminate bearing. The issue of bearing maintenance is eliminated with this arrangement. However, in order to mitigate the long term displacement due to creep/shrinkage, pre-setting back of both cantilever tips is adopted by using prejacking before closing the gap with the key segment.

3.3 Well Foundation

Based on detailed soil investigation, sub-surface profile along the main bridge corridor generally consists of loose, dense and very dense sand below the ground surface. Also hard and stiff clay layer is present in the upper part of ground at few boring locations. Scour is one of the governing parameter for stability and design adequacy check of well foundation. Scour is derived based on silt factor, design discharge (i.e. 106,839 cumecs as per hydraulic study) and width of water channel. Based on preliminary check of scour depth, well foundation depth has to be decided to proceed further design checks like Safe Bearing Capacity and Stability. Graphical representation of silt factors corresponding to different pier locations are shown in Figure. 5.

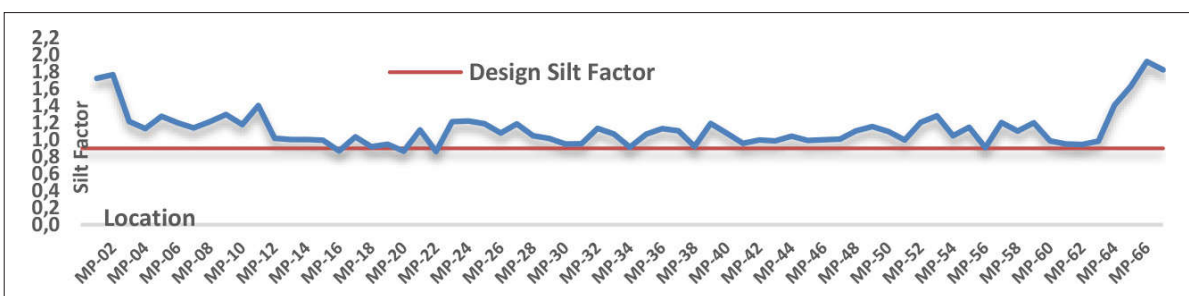

Figure 5 Silt Factor Distribution for all Pier Locations and Design Silt Factor

Accordingly, the design silt factor of 0.9 is finalized based on above graph. Then the scour parameters of the bridge are estimated based on hydrology data and geotechnical investigation report. Typical cross section of Double D well foundation is shown in Figure 6 with High flood level, Scour level, etc. The embedded portion of the well foundation from the scour level is called the grip length. In order to design the well foundation, the provisions in IRC 78:2014 [4] need to be satisfied prior to analysis of the complete model i.e. the minimum grip length, the maximum depth of scour and the minimum steining wall thickness. Stability checks are performed as per IRC: 45-1972 as the subsoil condition below scour occur cohesionless. Once the stability checks are satisfied then the structural design has to be done as per IRC 112:2011 [5].

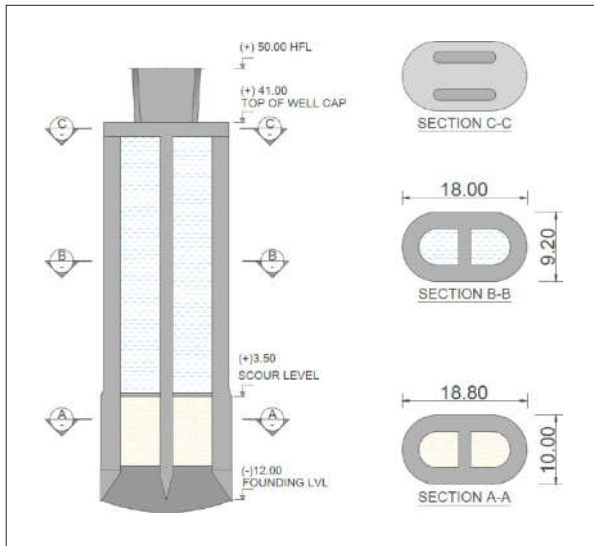
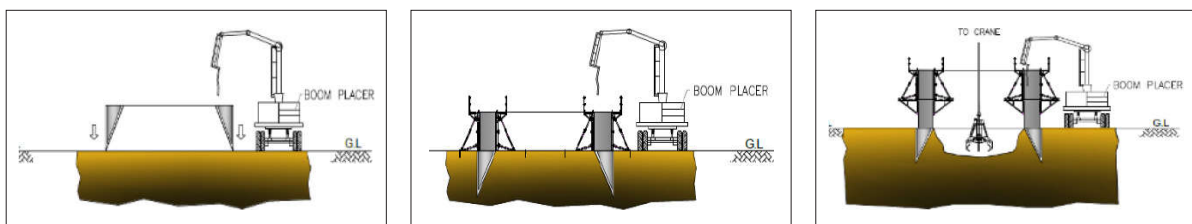

Figure 6 Well Foundation Details (All dimensions in m)

3.3.1 Methodology for sinking of well foundation

Construction Methodology adopted for well foundation includes self-sinking by gravity and specialized sinking methods. Additional sinking efforts like air and water jetting are considered to overcome the skin resistance of the well foundation during sinking as specialized sinking methods. The following are the sequence of activities and actual site photos related to well sinking.



a) Placing cutting edge on the ground

b) Sinking cutting edge and casting the steining wall

c) Sinking, Casting and dredging process

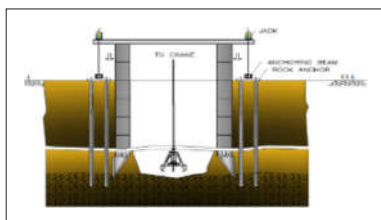

d) Setting rock anchors & beams with Hydraulic jack setup

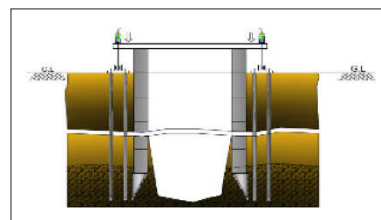

e) Sinking by hydraulic jack, casting of steining & dredging

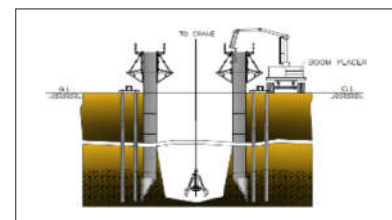

f) Completion of casting & Sinking up to founding level

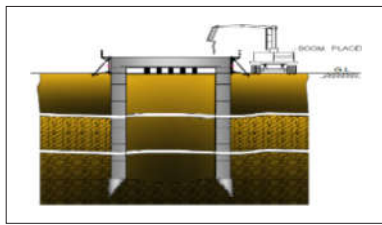

g) Completion of casting & Sinking up to founding level

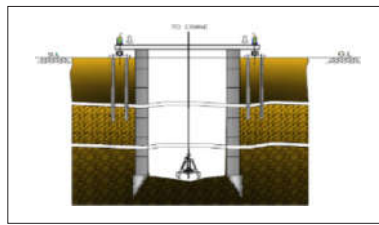

h) Sand filling & Casting of well cap



i) Rebar Arrangement (on site activities)



j) Concrete Pouring (on site activities)



k) Mucking & Sinking Arr. & ready for next lift (on site activities)

3.4 Needle Beam

For any typical block (Figure 3), proposed expansion joint at middle of span as shown in Figure.7. This type of joint is commonly used in balanced cantilever erection. Merit of this type joint is that the number of end span pier is minimized and there is no additional temporary structure required for end span erection. However, excessive deflection at joint in the middle of span mainly due to long term deflection induces discomfort to the drivers and also involves significant maintenance cost. To mitigate this concern about the expansion joint in the middle of span, a structural beam adopted as shown in the Figure 7. This beam once installed at final construction stage will restrain the deflection due to traffic loads and provide better comfort level to the driver as well.

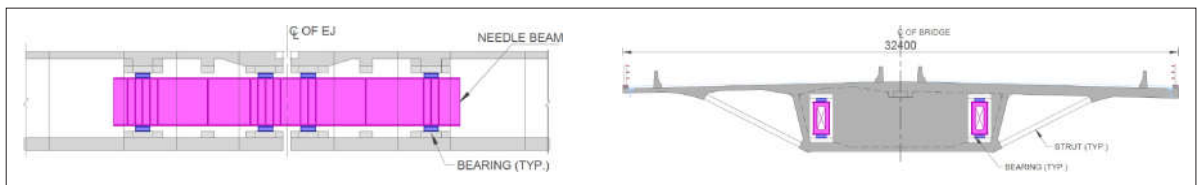

Figure 7 Needle Beam Arrangement near EJ

3.5 Stay cable

A single plane of cables consisting of $7 \times 2 = 14$ Nos. per pylon are located on the bridge centerline. Stay cables are planned to be tensioned from inside the deck and spaced at a distance 6 m along deck and 1.5 m along the pylon height. The cable design is verified in SLS, ULS and resistance verification for rupture of extradosed cable are done using SETRA Recommendations (SETRA 2001). In the present design condition, ULS condition is governing for the design of cable.

3.6 Methodology for erecting precast segments

The construction methodology of the typical block of main bridge involves the precast segmental balanced cantilever construction method using derrick crane. The pier table is constructed by cast-in situ method. The construction scheme proposed for the main bridge is shown in Figure. 8.

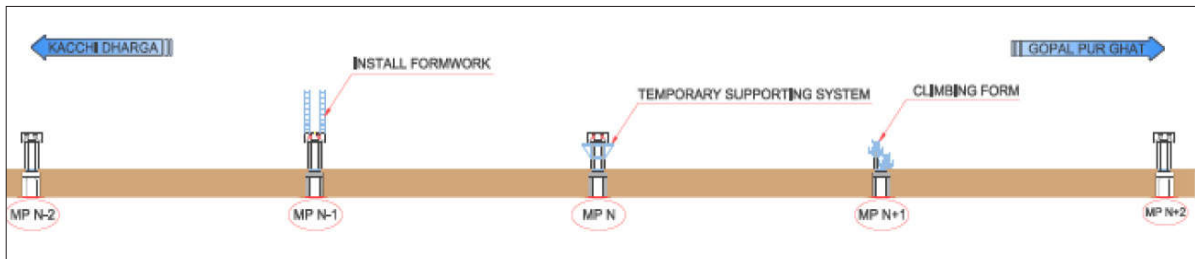

- a) Fabrication of reinforcing bar and casting concrete for lower pylon
- b) Installation of the temporary support system for pier table
- c) Construction of pier table and pylon

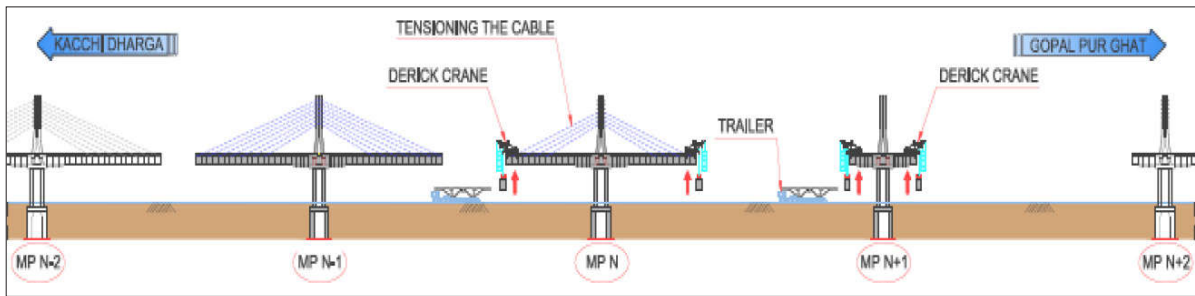

- d) Transportation of segments by trailer
- e) Installation of segment in due sequence by derrick crane
- f) Tensioning the cable and tendon in due sequence

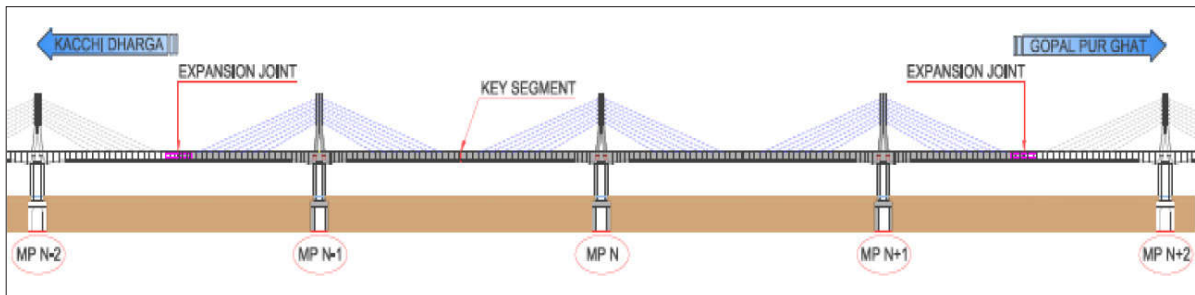

- g) Lifting of key segment formwork by derrick crane
- h) Lifting of internal movement joint
- i) Construction of key segment
- j) Installation of internal movement joint (Needle Beam)

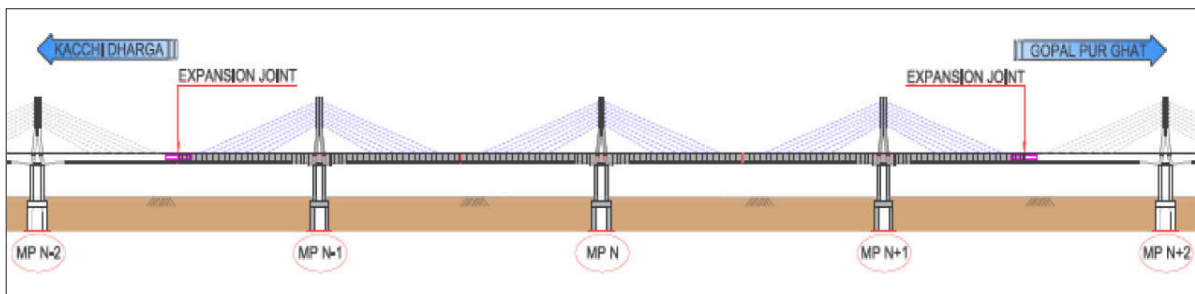

- k) Installation of the expansion joint
- l) Installation of wearing surface and road facilities

Figure 8 Construction methodology

The construction load considered in the analysis model is divided into two groups. One is for the stage by stage analysis and the other for stability check during construction. In general, construction loads are very varied and the IRC: 6[3] do not define the characteristic values of the construction loads for these kind of similar bridges. Thus for construction loads, Eurocode 1991-1-6 is referred.

4 Junction Development in Island

4.1 Need of connection with Island

Raghopur is an inhabited island with agricultural farms and villages sited between two perennial channels of River Ganga in Vaishali district in Bihar. At present the island is connected to Patna by pontoon bridge in dry season and by waterway during rest of the seasons. The need of connecting the island is essential not only based on present habitation but also for the future development of the Patna City as a satellite location to the City and at the same time the effect of flooding needs to be considered as per the past records can be addressed properly. Accordingly, it is decided to provide the facility platform immediately at the end of Ramps from Main Bridge which can be useful as rescue platform during floods.

4.2 Design development of Island Junction

Developing the junction in the Island over main bridge and connect the island on both sides with ramp structures is the challenging task in the project. At a junction block, the deck width has to be increased gradually to 52.2m as per IRC standards to facilitate connecting ramps. It should also satisfy the navigational criteria and client's requirement as extradosed bridge concept. The navigational clearance for each span needs to be maintained as the river can be meandering in any direction until it is guided in future with river training works. Developed the extradosed bridge design concept satisfies both the criteria as well as varying deck width as shown in Figure 9.

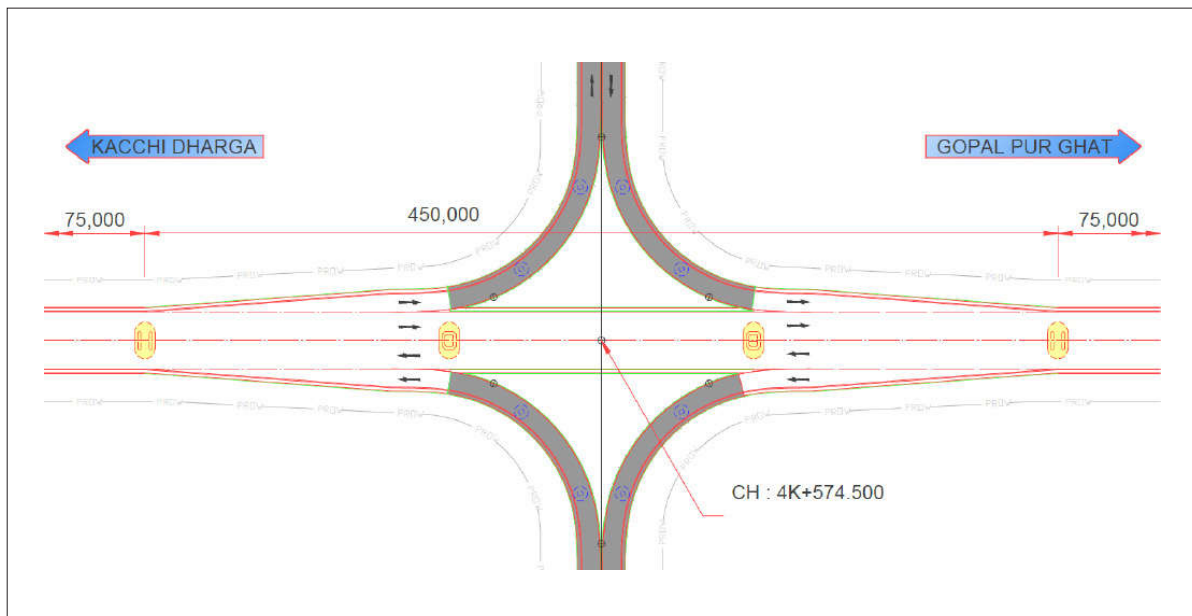

Figure 9 Junction Development in Island

5 Conclusion

Once construction is completed the six lane extradosed bridge would be the longest extradosed bridge in the world having total length of 9.759 km with 150 m each span. The project will become testimonial and one of the major landmarks for similar projects around the globe. Internal and external struts along with transverse tendons in top slab are adopted in decks in order to minimize the segment weight is one the best value engineering. Pier table monolithically connected with pylon tower thus eliminating the need of any bearing with recurring maintenance. Needle beam expansion joint at the mid span is adopted in design in order to provide smooth driving facility to the vehicles. Extradosed option is one of the best options for long spans between 100 m to 150 m than balanced cantilever deck with internal prestressing. This is also evidenced while carrying out various design options at the project design development stage.

This iconic bridge is well poised to become a global Bench Mark in long span bridge construction and will also be a source of encouragement to develop similar landmark bridges in India and elsewhere.

References

- [1] Feasibility report on project provided by client Bihar State Road Development Corporation Limited (BSRDCL).
- [2] Manual of specification and standards for six laning of highways through public private partnership – IRC SP 87 – 2013,
- [3] Standard specifications and code of practice for road bridges, section ii – loads and stresses – IRC 6 – 2014,
- [4] Standard specifications and code of practice for road bridges, section vii – foundations and substructure – IRC 78 – 2014,
- [5] Code of practice for concrete road bridges – IRC 112 – 2011,